



Steffen Haupt
Moritzer Straße 35 01589 Riesa-Poppitz
Tel. 03525/ 68 01 - 0 Fax: 03525/ 6801 - 20
e-mail: info@haupt-hydraulik.de
Internet: www.haupt-hydraulik.com

Druckspeicher, Zubehör und Ersatzteile

Englisch

HY10-4004/UK Rev.3



KATALOG

Vertrieb

Frau Krauspe
Frau Göhler

Tel.: 03525 680110
Tel.: 03525 680111

krauspe@haupt-hydraulik.de
goehler@haupt-hydraulik.de

Technischer Außendienst

Herr Burkhardt

Tel.: 03525 680112

burkhardt@haupt-hydraulik.de

Table of Contents

European Accumulator Catalogue 2014	I Table of Contents	2 - 3
	I Introduction	4 - 5
	I How to Size?	6
	I General Information Accumulators	7 - 10
I Bladder Accumulators Low Pressure Carbon Steel	I EBV Series: How to order a Low Pressure Accumulator	11
	I EBV Series 0,5 to 200 Litres, 40, 50 and 80 bar	12 - 13
	I EBV Series 100 to 575 Litres, 20 bar	14 - 15
	I EBV Series 100 to 575 Litres, 35 bar	16 - 17
I Bladder Accumulators Low Pressure Stainless Steel	I EBV Series 10 to 50 Litres, 14 bar	18 - 19
	I EBV Series 100 to 200 Litres, 14 bar	20 - 21
	I EBV Series 100 to 575 Litres, 14 bar	22 - 23
	I EBV Series 0,5 to 200 Litres, 20 & 40 bar	24 - 25
	I EBV Series Adaptors & Flanges	26 - 27
	I ELG and OLG Series 20 and 50 bar	28 - 29
I Bladder Accumulators High Pressure Carbon Steel	I EHV Series: General Information Bladder Accumulator	30
	I EHV Series: How to order a Bladder Accumulator	31
	I EHV Series 10 - 57 Litres, 330 bar	32 - 33
	I EHV Series 0,2 - 10 Litres, 350 bar	34 - 35
	I EHV Series 10 - 50 Litres, 480 bar	36 - 37
	I EHV Series 1 - 54 Litres, 690 bar	38 - 39
	I EHV Series 10 - 57 Litres, 330 bar, Flanged Fluid Port	40 - 41
	I EHV Series 2.5 - 10 Litres, 350 bar, Flanged Fluid Port	42 - 43
	I EHV-DA Series 10 - 57 Litres, 330 bar, High Flow	44 - 45
	I EHV-DA Series 2.5 - 10 Litres, 350 bar, High Flow	46 - 47
I Bladder Accumulators High Pressure Stainless Steel	I EHV Series 10 - 50 Litres, 70 bar	48 - 49
	I EHV Series 10 - 50 Litres, 110 bar	50 - 53
	I EHV Series 1 - 5 Litres, 120 bar	54 - 55
	I EHV Series Adaptors EHV & Flanges EHV	56 - 57
I Regulations & Protections	I Regulation Table EBV and EHV	58 - 59
	I Internal & External Protection	60
	I Bladder Mixes	61
I Piston Accumulators	I General Information Piston Accumulators	62
	I EHP Series: How to order a Piston Accumulators	63
	I EHP Series 60 to 400 Litres, 207 bar, ø 360	64 - 65
	I EHP Series 150 to 650 Litres, 220 bar, ø 540	66 - 67

	I EHP Series 0.3 to 4 Litres, 250 bar, ø 80	68 - 69
	I EHP Series 2 to 12 Litres, 250 bar, ø 100	70 - 71
	I EHP Series 4 to 25 Litres, 250 bar, ø 140	72 - 73
	I EHP Series 8 to 50 Litres, 250 bar, ø 180	74 - 75
	I EHP Series 10 to 150 Litres, 250 bar, ø 195	76 - 77
	I EHP Series 10 to 150 Litres, 250 bar, ø 200	78 - 79
	I EHP Series 25 to 200 Litres, 250 bar, ø 250	80 - 81
	I EHP Series 30 to 500 Litres, 250 bar, ø 350	82 - 83
	I EHP Series 2 to 10 Litres, 350 bar, ø 100	84 - 85
	I EHP Series 8 to 50 Litres, 350 bar, ø 180	86 - 87
	I EHP Series 25 to 200 Litres, 350 bar, ø 250	88 - 89
	I EHP Series 30 to 350 Litres, 350 bar, ø 350	90 - 91
	I Regulations for EHP Piston Accumulators	92 - 93
	I A Series: How to order a Piston Accumulator	94
	I A Series 0.5 to 300 Litres, 250 bar	95
	I AP Series: How to order a Piston Accumulator	96
	I AP Series 0.1 to 150 Litres, 350 bar	97
	I ACP Series: How to order a Piston Accumulator	98
	I ACP Series 0.08 to 8 Litres, 275 bar (260 bar)	99
I Attenuators	I General Information Attenuators	100
	I SH Series: How to order a Attenuator	101
	I SH Series 350 bar	102 - 103
I Diaphragm Accumulators	I General Information Diaphragm Accumulator	104
	I ELM Series: How to order a Diaphragm Accumulator	105
	I ELM Series 0.075 to 1.4 Litres	106 - 107
	I ELM Series 1.4 to 3.5 Litres	108 - 109
	I ELM Series 0.075 to 1.4 Litres	110 - 111
	I ELM Series 1.4 to 3.5 Litres	112 - 113
I Accessories	I Clamps	114 - 117
	I Support Brackets & Mounting Frames	118 - 119
	I Charging Set VGU	120 - 121
	I Safety Blocks	122 - 141
	I Gas Bottles	142 - 147

Note: When you have any questions about the products in this catalogue, please send your question to:
CommercialSupportAccuACDE@parker.com

Introduction

Solutions developed by Parker Olaer are used in a large number of industrial sectors: aeronautics, chemistry, defence, mining, railway construction, Formula 1, machine tools, agriculture, oil and gas, metallurgy, renewable energies, etc.

This variety of applications requires extensive knowledge of the products and their major components, particularly the bladder. In order to reinforce its position, Parker Olaer is the co-owner of its main bladder supplier. For either a standard application or designing solutions for a specific requirement, Parker Olaer engineers have the experience in elastomers and

knowledge of the latest technological developments in metal and composite shells. This allows Parker Olaer to propose reduced weight accumulators and other design innovations.

We provide cost effective solutions based upon our customer's needs. Parker Olaer utilizes comprehensive tools and resources including an applications database, CAD/CAM, finite element analysis, reliability studies and simulation software which enable us to optimize design and performance.



Parker ACDE Colomnes (Paris, France)

The historical cradle of Olaer Industries, which is now Parker ACDE Paris.

Manufacture:

- Bladder Accumulators
- Diaphragm Accumulators
- Low Pressure Bladder Accumulators up to 575 litres
- Attenuators
- Special Accumulators for aerospace and racing
- Accessories
- Accumulator Systems

Paris, France Bladder accumulators for wind and some mobile CE approval (Europe), SELO approval (China) others under development.



Parker ACDE Hellaby (Bramley, UK)

Historically a part of Cylinder Division, then the Global Accumulator Division.

Manufacture:

- Piston accumulators up to Ø 360 mm / 350 bar
- Crimped piston technology
- Bladder accumulators
- Diaphragm accumulators
- Safety blocks
- Accessories

Parker Hellaby, UK (Parker GAD) Focus on piston accumulators industry & mobile CE Approval – others under development. Diameters ≤ 360 mm and pressures ≤ 350 bar. Crimped piston accumulators 275 bar < 20 Litres.



Parker ACDE Sandycroft (Chester, UK)

250 year history as a company.

Focus on: Oil & Gas markets globally + UK market with their own gas valves and fluid ports.

Manufacture:

- Bladder Accumulators - forged, welded and machined
- Piston Accumulators in various materials and pressures
- Pulsation Dampers
- Pressure Compensators
- Safety Blocks – Carbon Steel and Stainless Steel
- Various other accessories & Accumulator Systems
- Large variety of approvals

Parker ACDE Sandycroft, UK Focus on Oil & Gas + specials. Special materials, diameters > 250 - 600 mm for any pressures Any diameter at pressures > 400 bar. Pressure up to 3000 bar available. Special pressure vessel approvals available.



Parker ACDE Leini (Turin, Italy)

47 year history.

Manufacture:

- Welded Bladder Accumulators low pressure up to 35 bar CS/SS
- Welded Bladder Accumulators high pressure (up to 220 bar) CS/SS
- Piston Accumulators CS and SS, up to 350 bar / up to 540 mm bore
- Pulsation Dampers
- Piston / Bladder accumulator systems.
- Gas bottle systems
- Large variety of approvals (PED & ASME most requested)

Parker ACDE Leini Focus on Oil & Gas, Industrial, Special welded pressure vessels/tanks on customer needs Racks.

How to size

How to size?

Parker Olaer has developed very sophisticated simulation software to optimize accumulator sizing recommendations. The behaviour of accumulators used in applications such as pulsation dampening, surge alleviation, thermal expansion and energy storage can be simulated. Our software can be downloaded from our website www.parker.com/ACDE. You may also contact your local Parker Olaer office for sizing assistance.

The graph is useful to estimate the size of an accumulator used to store or deliver a specific volume of liquid within a given pressure range. These curves are the graphic representation of an adiabatic cycle (fast cycling rate - $N = 1.4$ perfect gas assumption) or isothermal cycle for an accumulator working at 20°C with a Pre-charge $P_0 = 0,9 P_1$.

They do not take into consideration the real gas compression correction factor, the real adiabatic coefficient and the polytropic rate of the application. Depending on the application data, the influence of these factors may be significant, and require that some calculations adjustments be made. The Parker Olaer simulation software takes all these factors into account.

***Reminder**

Isothermal: The transformation is said to be isothermal when the compression or expansion of the gas occurs at a rate slow enough to allow a good thermal exchange, allowing the gas to remain at constant temperature.

Adiabatic: The transformation is said to be adiabatic when the cycle is quick and does not allow a temperature exchange with the ambient media.

Sizing of an accumulator to be installed in the following example conditions:

P2 : Maximum available pressure : 210 Bar

P1 : Minimum working pressure : 100 Bar

P0 : Nitrogen Pre-charge : 90 Bar

ΔV : Volume to be stored : 14L

Condition : Isothermal (No temperature variation)

A/Compression ratio $\alpha = P_2/P_1 = 210/100 = 2,1$

B/From the value 2,1 on the α axis, draw a vertical line that intersects the isothermal reference curve in A.

C/From the value 14 on the ΔV axis, draw a vertical line. The intersection point of this line with the horizontal line meeting A indicates a required accumulator size of 32 L.

Calculation of the volume drawn off from an accumulator.

Accumulator size = 12 L

P2 = 185 Bar; P1 = 100 Bar;

P0 = 90 Bar; Adiabatic condition

$\alpha = P_2/P_1 = 185/100 = 1,85$

ΔV : 3,5 litres

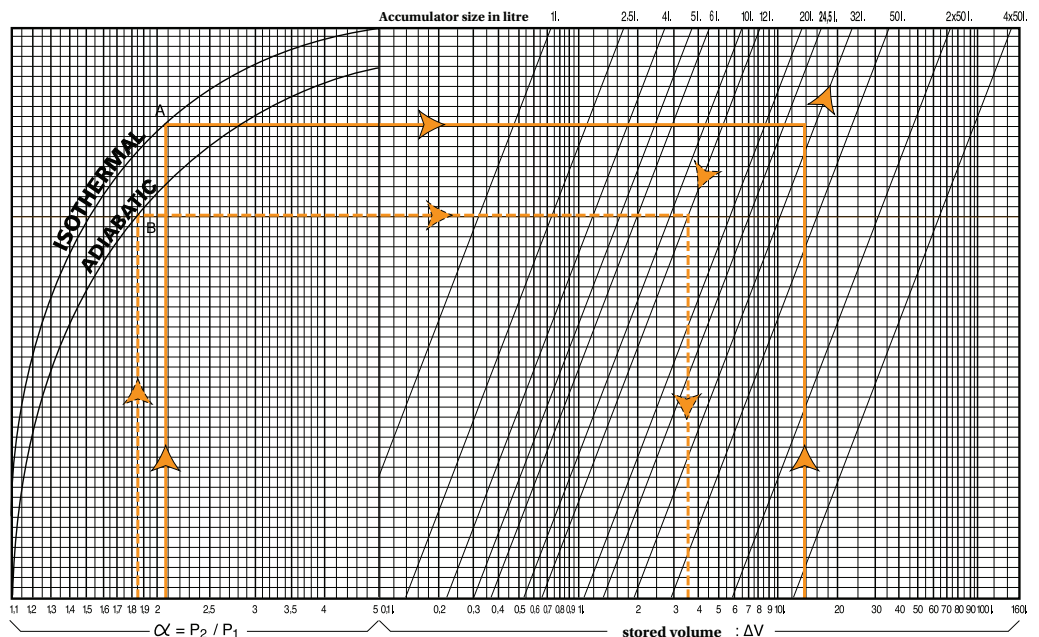

Basic sizing chart for accumulator used in energy storage.

General Information Accumulators

Olaer, pioneer of high pressure equipment, was founded in 1938 by Jean Mercier. Using his experience, passion for research and extensive knowledge of hydraulics in the demanding field of aeronautics, Mr. Mercier engineered the first gas loaded bladder accumulator. This has led to Olaer becoming the indisputable international leader in this field.

This variety of applications requires extensive knowledge of the products and their major components, particularly the bladder. In order to reinforce its position, Olaer is the co-owner of its main bladder supplier. For either a standard application or designing solutions for a specific requirement, Parker Olaer engineers have the experience in elastomers and knowledge of the latest technological developments in metal and composite shells. This allows Parker Olaer to propose reduced weight accumulators and other design innovations.

We provide cost effective solutions based upon our customer's needs. Parker Olaer utilizes comprehensive tools and resources including an applications database, CAD/CAM, finite element analysis, reliability studies and simulation software which enable us to optimize design and performance.

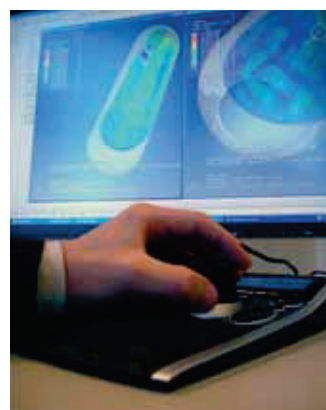

Operation

The Olaer gas loaded accumulator is an essential component for the optimum operation of a hydraulic circuit. In hydraulic circuits, the accumulator enables:

- An energy reserve which is instantaneously available to the system.
- Compensation of pressure fluctuations and spikes.
- Pump pulsation dampening.

Advantages/Your benefits

The gas loaded bladder accumulators provide major advantages in terms of the energy output of the device and maintenance of the installation:

- **Reduction in working costs**
 - Reduces installed electrical power
 - Significant energy saving
- **Increase lifetime of equipment**
 - Reduces pulsations
 - Protects against pressure peaks
- **Reduction in maintenance cost**
 - Reduces wear of hydraulic components
 - Requires minimum maintenance of the installation

Operating principle

Operation of the Olaer gas loaded bladder accumulator is based on the considerable difference in compressibility between a gas and a liquid, enabling a large quantity of energy to be stored in an extremely compact form. This enables a liquid under pressure to be accumulated, stored and recovered at any time.

Its special design allows the bladder (the strategic component) to compress the gas and usually form into three lobes in order for the accumulator to store, then to deliver the fluid under pressure, as required.

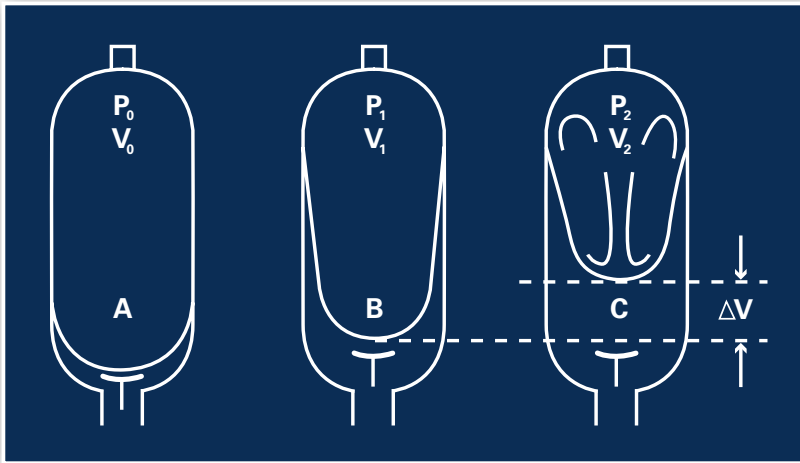

- V₀** = Capacity in nitrogen of the accumulator
- V₁** = Gas volume at the minimum hydraulic pressure
- V₂** = Gas volume at the maximum hydraulic pressure
- ΔV** = Returned and/or stored volume of working fluid between P₁ and P₂
- P₀** = Initial preload of the accumulator
- P₁** = Gas pressure at the minimum hydraulic pressure
- P₂** = Gas pressure at the maximum hydraulic pressure

A - Bladder in the Pre-charge position, which means that the accumulator only contains nitrogen. The anti-extrusion system closes the hydraulic orifice which prevents the destruction of the bladder. In low pressure accumulators the bladder rests against the grid.

Maximum pressure differential (P₂/P₀): 4:1

B - Position at the minimum operating pressure. There must be a certain amount of fluid between the bladder and the hydraulic orifice, such that the anti-extrusion system does not close the hydraulic orifice.

C - Position at the maximum operating pressure. The volume difference between the minimum and maximum positions of the operating pressures represents the working fluid quantity.

Technical Characteristics

The accumulator comprises of a pressure vessel including valve stem device, a rubber bladder and an anti-extrusion system.

- Shell material options include alloyed steel, stainless steel, aluminium, titanium and composites.
- Various bladder materials available which are compatible with a range of fluids and temperatures.
- Different anti-extrusion systems can be used for specific applications (fluidport assembly for high pressure, grid for low pressure, or button).

Taking into account the different needs of various applications, Parker Olaer proposes different protections external and/or internal: Bare metal, nickel plating, epoxy paint, PTFE, Rilsan® and phenolic coating. This extensive range enables us to offer accumulators operating from - 50 to +150°C with pressures of up to 1500 Bar and capacities of up to 575 litres.

As the market leader in bladder type accumulators, Parker Olaer has participated in the development of the EN 14359:2006 standard, which specifies the material, design, manufacturing, fatigue tests, safety devices and documentation (including the instruction manual), for pressure accumulators and gas bottles for hydraulic applications.



Different elastomer options

Parker Olaer can offer many different elastomer options depending on the application where the product is used. Two of the most important parameters for deciding the rubber compound to be used is:

1. The minimum and maximum operating temperature of the system.
2. The fluid type in the system.

The most common bladder for hydraulic systems with mineral oil is Nitrile (also called NBR or Buna). A host of other rubbers such as Butyl, Hydrin®, Viton® or EPDM and more are available. Please contact your local Parker Olaer office for your specific application.

Also, be sure to note that even if you change the bladder to one with particularly high or low temperature characteristics, the pressure vessel temperature range (TS) does not change. Check that the operating temperature range of the new chosen bladder is included in the temperature range of the pressure vessel.

Regulations and Approvals

Parker Olaer designs and manufactures gas loaded accumulators for use in all countries, as well as other industry specific approvals including oil & gas, naval and nuclear. The main regulations in force are PED for European market, ASME for US market and SELO for Chinese market.

As a service, Parker Olaer can recommend the appropriate regulations applicable if customers know the country where the accumulator will be installed.

When operating in dangerous and explosive environments, Parker Olaer has designed an ATEX Group II cat. 2 and 3 range of accumulators.

Some of these regulations call for the use of safety devices to protect the accumulator against over pressure. Solutions may include hydraulic safety blocks, relief valves or gas side safety devices such as burst discs and fuse plugs.

Parker Olaer has designed and proposed a complete range of safety devices suitable for the applicable regulations.

To meet the needs of our customers, Parker Olaer can supply accumulators with multiple approvals.

With regard to environmental concerns Parker Olaer’s product range complies with REACH regulations.

Each accumulator is delivered with the certificate of conformity.

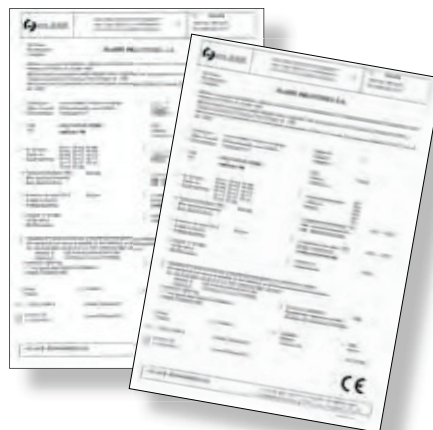

Top Repairable accumulators

This accumulator type can be serviced from both the fluid side or the gas side. The design utilizes many standard accumulator parts, but is unique in that it does not have to be removed from the system in order to change the bladder. This can in many applications be a great advantage. The gas end adaptor mechanically locks to prevent disassembly under pressure.



High flow bladder accumulators

Parker Olaer has several versions of bladder accumulators for high flow applications, depending on how high the flow requirements will be. The first step up from our standard is a high flow version with a 2" fluid port, where the internal geometrics of the port body and poppet valve are specifically designed for that purpose. The next step is a 2 1/2 " fluid port which will provide even higher flows. For ultimate demands a 4" fluid port can also be provided. Please note that the last two solutions require shells with larger openings, and are not always available in all shell sizes. Parker Olaer can tailor make the different parts to suit your technical needs.



Transfer barrier

This range is a special adaptation of the bladder accumulator, with a pipe connected to the gas side of the accumulator. The most common application is to use the transfer accumulator in energy storage applications. The accumulator is connected to an additional volume of nitrogen, for example a gas cylinder. This increases the total volume of the system. Such systems are often mounted together in a battery or rack type installation.

A Transfer Barrier Accumulator can also be used to separate two liquids or a gas and liquid. It is usually a question of separating two liquids, one of which is aggressive or contaminated. To limit the number of parts in contact with the aggressive liquid, it is common practice to put the aggressive fluid inside the bladder and therefore connect on what is normally the gas side.

Dependant upon the accumulator volume, the displaced volume must not exceed 80% of the volume of the transfer accumulator.

EBV Series: How to order a low pressure accumulator

Technical Characteristics

The accumulator comprises a forged or welded steel shell, a rubber bladder and anti-extrusion system.

- Shell material options include alloyed steel, stainless steel, aluminium, titanium and composites.
- Various bladder materials available which are compatible with a range of fluids and temperatures.
- Anti-extrusion system: perforated bushing.

In standard versions : shell in steel, bladder and rings in nitrile for functioning with mineral oils.

Operating temperature : - 20°C + 100°

Special constructions : consult Parker Olaer

Volume from 0.2 to 200 Litres

Pressure from 20 to 80 Bars

Nitrogen gas pressure : Never precharge accumulator at a pressure exceeding 20 bar at maximum working temperature

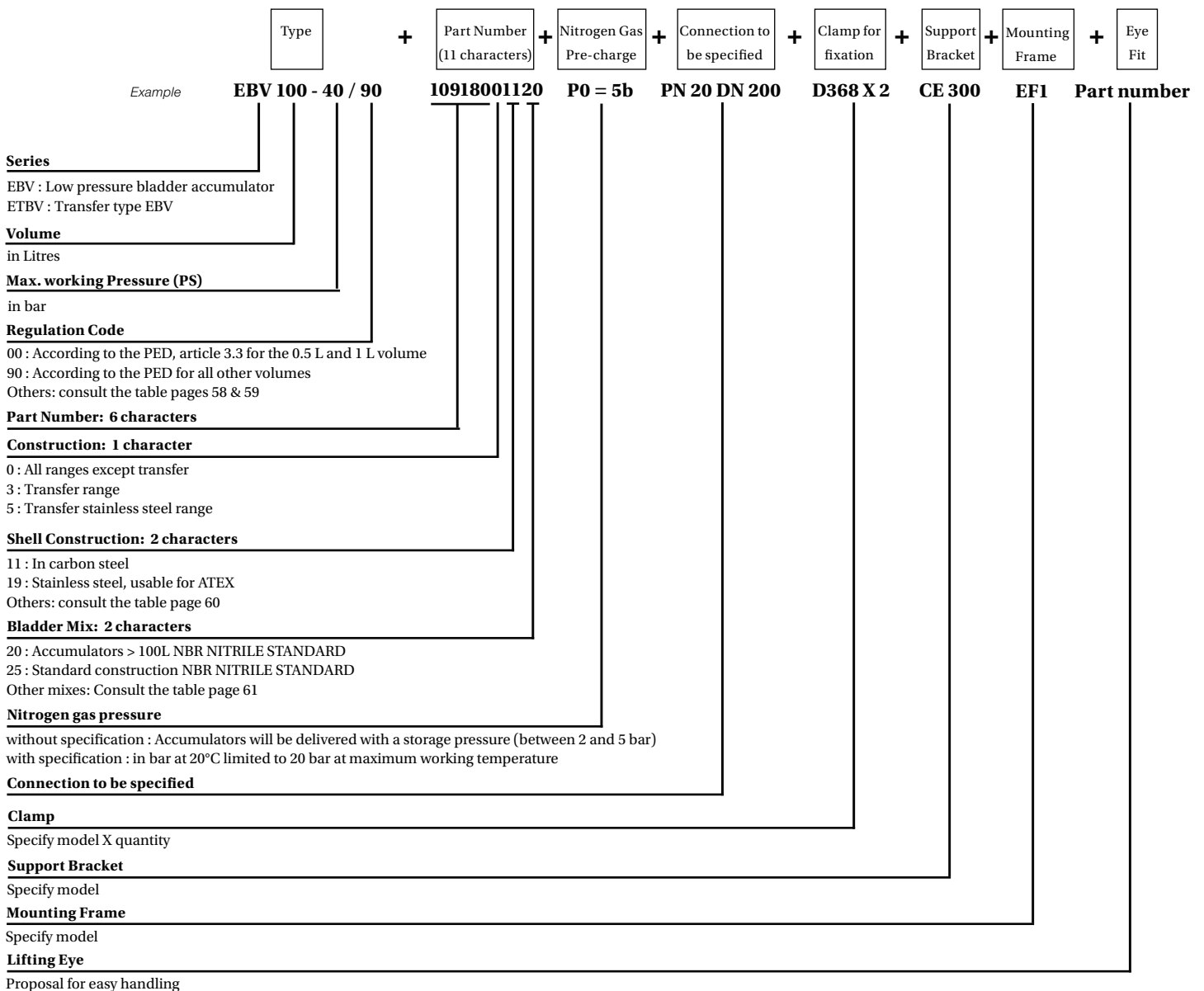

EBV Series 40, 50 & 80 bar, 0.5 to 200 Litres

Standard version (**Carbon Steel** shell/NBR mix) for mineral oils temperature from - 20° up to 100°C
 According to PED 97/23/EC, Fluid Group 2
Part numbers, Accessories, Dimensions

Type	Valve model see drawing	Pre-charge 1 - 20 bar	Adaptor Threaded Part number	Flange		Clamps Model (quantity) Part number	Support Bracket Model Part number	Lifting Eye on gas side Model Part number	Complete Repair Kit Model Part number
				Model Part number	Model Part number				
EBV 0.5-50/00*	D	751052	G 1" cyl 04557000223	-	-	E95 (1) 20250803648	-	-	KIT EBV 0.5-50/00 19002900225
EBV 1-80/00*	C	751053	G 1" cyl 04557000223	1½" ANSI 150 lbs 04542000123	1½" ANSI 300 lbs 04524100123	E114 (1) 20251003648	CE 89 20151903620	-	KIT EBV 1-80/00 19044300225
EBV 2.5-80/90	C	751054	G 1" cyl 04557000223	1½" ANSI 150 lbs 04542000123	1½" ANSI 300 lbs 04524100123	E114 (2) 20251003648	CE 89 20151903620	-	KIT EBV 2.5-80/90 19044400225
EBV 5-80/90	C	751056	G 1" cyl 04557000223	1½" ANSI 150 lbs 04542000123	1½" ANSI 300 lbs 04524100123	E114 (2) 20251003648	CE 89 20151903620	-	KIT EBV 5-80/90 19044500225
EBV 10-40/90	A	751057	G 2" cyl 04570300223	4" ANSI 150 lbs 04500300123	4" ANSI 300 lbs 04520800123	D215 (2) 20251403648	CE 159A 20109003620	10912700200	KIT EBV 10-40/90 19043900225
EBV 20-40/90	A	751058	G 2" cyl 04570300223	4" ANSI 150 lbs 04500300123	4" ANSI 300 lbs 04520800123	D215 (2) 20251403648	CE 159A 20109003620	10912700200	KIT EBV 20-40/90 19044000225
EBV 32-40/90	A	751059	G 2" cyl 04570300223	4" ANSI 150 lbs 04500300123	4" ANSI 300 lbs 04520800123	D215 (2) 20251403648	CE 159A 20109003620	10912700200	KIT EBV 32-40/90 19044100225
EBV 50-40/90	A	751060	G 2" cyl 04570300223	4" ANSI 150 lbs 04500300123	4" ANSI 300 lbs 04520800123	D215 (2) 20251403648	CE 159A 20109003620	10912700200	KIT EBV 50-40/90 19054700225
EBV 100-40/90	A	751061	-	8" ANSI 150 lbs 04500800123	8" ANSI 300 lbs 04500900123	D368 (2) 20127403625	CE 300 20150800100	-	KIT EBV 100-40/90 19044600220
EBV 200-40/90	A	751062	-	8" ANSI 150 lbs 04500800123	8" ANSI 300 lbs 04500900123	D368 (2) 20127403625	CE 300 20150800100	-	KIT EBV 200-40/90 19044700220

* according to the PED, article 3.3

Model of valve stem
5/8" 18 UNF
(A)



Model of valve stem
7/8" 14 UNF
(C)

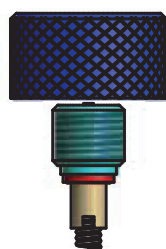

Model of valve stem
5/8" 18 UNF
(D)



Accumulators are delivered with the nitrogen pre-charge 3 bar.
 The charging pressure for low pressure accumulators must never exceed 20 bar at the maximum operating temperature.

Type	Effective Gas vol. Litres	Max. Working pressure (PS) bar	Max Weight kg	O-ring \varnothing int x \varnothing tore	Dimensions in mm							
					A max height	B	C	\varnothing D max	\varnothing d	G connection	\varnothing H	
EBV 0.5-50/00*	0.5	50	3	54 x 3	245	52	28	90	16	G2" cyl.	68	
EBV 1-80/00*	1	80	5	54 x 3	310	47	66	116	22.5	G2" cyl.	68	
EBV 2.5-80/90	2.3	80	10	54 x 3	484	47	66	116	22.5	G2" cyl.	68	
EBV 5-80/90	5	80	17	54 x 3	867	47	66	116	22.5	G2" cyl.	68	
EBV 10-40/90	10	40	13	96 x 4	454	51	75	212	22.5	G3½" cyl.	120	
EBV 20-40/90	18	40	22	96 x 4	776	51	75	212	22.5	G3½" cyl.	120	
EBV 32-40/90	34	40	37	96 x 4	1307	51	75	212	22.5	G3½" cyl.	120	
EBV 50-40/90	50	40	51	96 x 4	1829	51	75	212	22.5	G3½" cyl.	120	
EBV 100-40/90	90	40	124	196.21 x 5.33	1317	158	93	371	80	M205x3	224	
EBV 200-40/90	207	40	215	196.21 x 5.33	2529	158	93	371	80	M205x3	224	

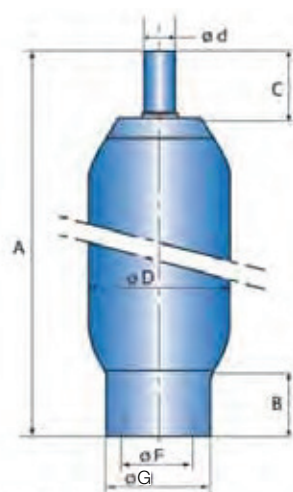

Above dimensions are in mm and are subject to manufacturing tolerances.

EBV Series 20 bar, 100 to 575 Litres

Standard Version (**Carbon Steel** shell/Mix NBR) according to PED 97/23/CE compliant

EN 14359 Fluid Group 2

Part numbers, Accessories, Dimensions

Type	Pre-charge	Adaptor	Flange		Clamps	Support Bracket	Lifting Eye on gas side	Complete Repair Kit
Part number	1 - 20 bar	Threaded Part number	Model Part number	Model Part number	Model (quantity) Part number	Model Part number	Model Part number	Model Part number
EBV 100-20/90			Consult Division					KIT EBV 100-20/90
Consult Division								190504
EBV 150-20/90			Consult Division					KIT EBV 150-20/90
10962202020								190505
EBV 200-20/90			Consult Division					KIT EBV 200-20/90
10962302020								190506
EBV 300-20/90			Consult Division					KIT EBV 300-20/90
10962401130								19050700225
EBV 375-20/90			Consult Division					KIT EBV 375-20/90
10962501125								19050800225
EBV 475-20/90			Consult Division					KIT EBV 475-20/90
10962601125								1905090025
EBV 500-20/90			Consult Division					KIT EBV 500-20/90
10962701120								19051000225
EBV 575-20/90			Consult Division					KIT EBV 575-20/90
10962801120								190511

Accumulators are delivered with the nitrogen pre-charge 3 bar.

The charging pressure for low pressure accumulators must never exceed 20 bar at the maximum operating temperature.

Type	Effective Gas vol. Litres	Max. Working pressure (PS) bar	Max Weight kg	Dimensions in mm									
				A max height	B	C	øD max	ød	øE	øH	S	T	
EBV 100-20/90	93	20	145	824	244	-	561	291,5	255	160	430	350	
EBV 150-20/90	139	20	170	1027	345,5	-	561	373	295	160	430	350	
EBV 200-20/90	207	20	208	1326	465	752	561	600	295	224	200	120	
EBV 300-20/90	293	20	253	1702	522	1128	561	668	295	224	200	120	
EBV 375-20/90	379	20	300	2083	522	1509	561	1049	295	224	200	120	
EBV 475-20/90	473	20	350	2497	522	1923	561	1463	295	224	200	120	
EBV 500-20/90	532	20	380	2756	522	2182	561	1722	295	224	200	120	
EBV 575-20/90	565	20	400	2905	522	2231	561	1871	295	224	200	120	

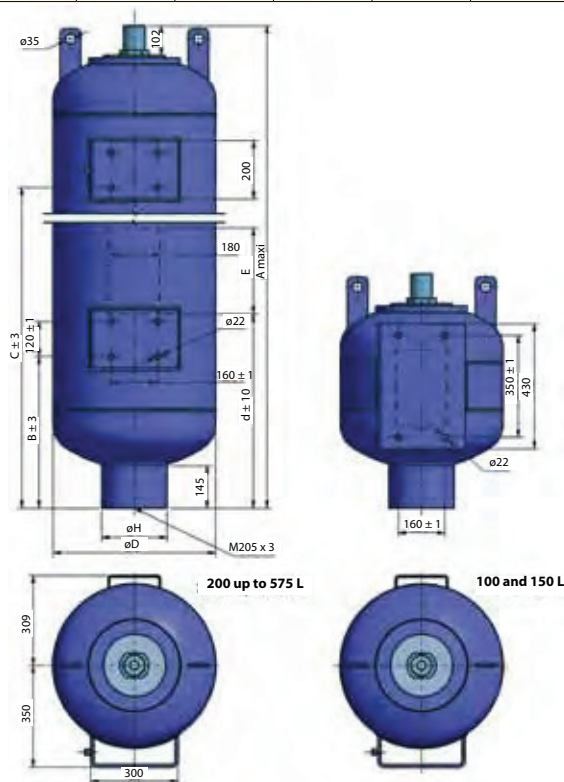

Above dimensions are in mm and are subject to manufacturing tolerances.

EBV Series 35 bar, 100 to 575 Litres

Standard version (**Carbon Steel** shell/bladder for mineral oils) temperature from - 20° up to 100°C
 According to PED 97/23/EC, Fluid Group 1/2
Part numbers, Accessories, Dimensions

Type Part number	Flange	Complete Repair Kit	
		Part number	
EBV 100.35/90 J41000355419R25	Welded flange 4" #150RF other available upon request.	8590009-xyyy	
EBV 150.35/90 J41500355419R25		8590010-xyyy	
EBV 200.35/90 J42000355419R25		8590011-xyyy	
EBV 300.35/90 J43000355419R25		8590013-xyyy	
EBV 375.35/90 J43750355419R25		8590014-xyyy	
EBV 475.35/90 J44750355419R25		8590015-xyyy	
EBV 575.35/90 J45750355419R25		8590017-xyyy	

Type	Effective Gas vol. Litres	Design P bar	Max Weight kg	L (mm)	øD max (mm)	B	C
EBV 100.35/90	103	35	188	556	560	260	175
EBV 150.35/90	154	35	220	759	560	260	175
EBV 200.35/90	205	35	271	1058	560	260	175
EBV 300.35/90	303	35	339	1448	560	260	175
EBV 375.35/90	377	35	397	1815	560	260	175
EBV 475.35/90	478	35	463	2230	560	260	175
EBV 575.35/90	579	35	525	2638	560	260	175



EBV Series 14 bar, 10 to 50 Litres

Standard version (**Stainless Steel** shell/bladder for mineral oils) temperature from - 20° up to 100°C

According to PED 97/23/EC, Fluid Group 1/2

Part numbers, Accessories, Dimensions

Type Part number	Adaptor	Flange	Clamps	Support Bracket	Complete Repair Kit
			Model (quantity) Part number	Model Part number	Part number
EBV 10.14/90 J4010014500XR25	Various adaptors and flanges available		D215 (2) 20251403648	CE 159A 20109003620	8590001-xyyy
EBV 12.14/90 J4012014500XR25			D215 (2) 20251403648	CE 159A 20109003620	8590002-xyyy
EBV 20.14/90 J4020014500XR25			D215 (2) 20251403648	CE 159A 20109003620	8590003-xyyy
EBV 24,5.14/90 J4245014500XR25			D215 (2) 20251403648	CE 159A 20109003620	8590004-xyyy
EBV 32.14/90 J4032014500XR25			D215 (2) 20251403648	CE 159A 20109003620	8590005-xyyy
EBV 50.14/90 J4050014500XR25			D215 (2) 20251403648	CE 159A 20109003620	8590006-xyyy

Type	Effective Gas vol. Litres	Design P bar	Max Weight kg	L (mm)	øD max (mm)	B	C	Or Fluid side*
EBV 10.14/90	9	14	16	324	215	57	66	96 x 3
EBV 12.14/90	11	14	20	435	215	57	66	96 x 3
EBV 20.14/90	18	14	27	645	215	57	66	96 x 3
EBV 24,5.14/90	22.5	14	32	815	215	57	66	96 x 3
EBV 32.14/90	32	14	44	1180	215	57	66	96 x 3
EBV 50.14/90	48.5	14	62	1695	215	57	66	96 x 3

* Supplied if adaptor/flange is assembled.



EBV Series 14 bar, 100 and 200 Litres

Standard version (**Stainless Steel** shell/bladder for mineral oils) temperature from - 6° up to 100°C

According to PED 97/23/EC, Fluid Group 1/2

Part numbers, Accessories, Dimensions

Type Part number	Adaptor	Flange	Clamps	Support Bracket	Complete Repair Kit
			Model (quantity) Part number	Model Part number	Part number
EBV 100.14/90	Various adaptors and flanges available		D368 (2)	CE 300	8590007-xyyy
J4100014500XR25			20127403625	20150800100	
EBV 200.14/90			D368 (2)	CE 300	8590008-xyyy
J4200014500XR25			20127403625	20150800100	

Type	Effective Gas vol. Litres	Design P bar	Max Weight kg	L (mm)	øD max (mm)	C	Or Fluid side*
EBV 100.14/90	97	14	85	1215	368	95	196 x 3
EBV 200.14/90	196.5	14	154	2427	368	95	196 x 3

* Supplied if adaptor/flange is assembled.

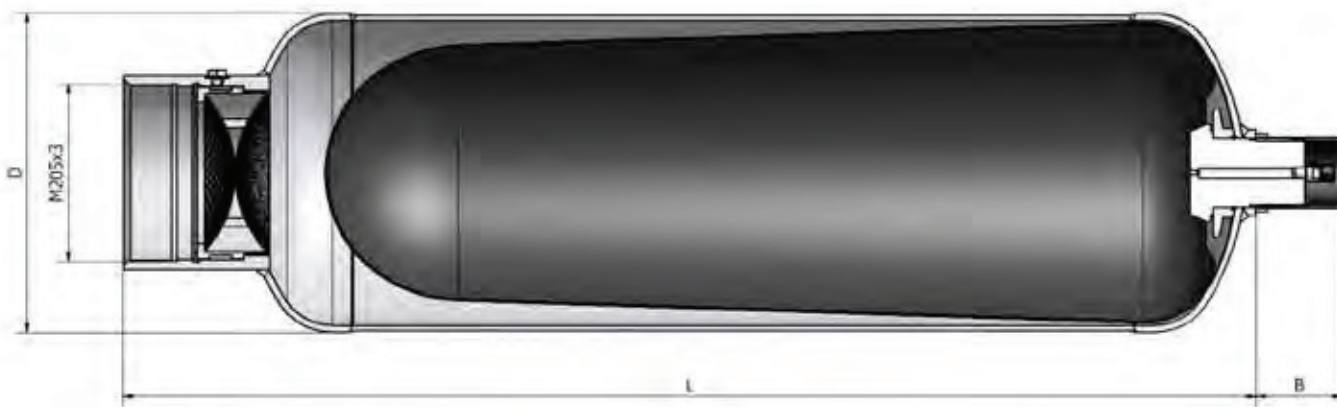

EBV Series 14 bar, 100 to 575 Litres

Standard version (**Stainless Steel** shell/bladder for mineral oils) temperature from - 20° up to 100°C
 According to PED 97/23/EC, Fluid Group 1/2
Part numbers, Accessories, Dimensions

Type Part number	Flange	Complete Repair Kit	
		Part number	
EBV 100.14/90 J41000145419R25	Welded flange 4" #150RF other available upon request.	8590009-xyyy	
EBV 150.14/90 J41500145419R25		8590010-xyyy	
EBV 200.14/90 J42000145419R25		8590011-xyyy	
EBV 300.14/90 J43000145419R25		8590013-xyyy	
EBV 375.14/90 J43750145419R25		8590014-xyyy	
EBV 475.14/90 J44750145419R25		8590015-xyyy	
EBV 575.14/90 J45750145419R25		8590017-xyyy	

Accumulators shall be provided with Welded brackets or legs.

Type	Effective Gas vol. Litres	Design P bar	Max Weight kg	L (mm)	øD max (mm)	B	C
EBV 100.14/90	103	14	129	556	560	260	175
EBV 150.14/90	154	14	153	759	560	260	175
EBV 200.14/90	205	14	187	1058	560	260	175
EBV 300.14/90	303	14	234	1448	560	260	175
EBV 375.14/90	377	14	274	1815	560	260	175
EBV 475.14/90	478	14	320	2230	560	260	175
EBV 575.14/90	579	14	365	2638	560	260	175



EBV Series 20 & 40 bar, 0,5 to 200 Litres

Standard Version (**Stainless Steel/NBR Mix**) according to PED 97/23/CE compliant

EN 14359 Fluid Group 2

Part numbers, Accessories, Dimensions

Type	Pre-charge	Adaptor	Flange		Clamps	Support Bracket	Lifting Eye on gas side	Complete Repair Kit
	1 - 20 bar		Model	Model				
Part number		Threaded Part number	Model Part number	Model Part number	Model Part number	Model Part number	Model Part number	Model Part number
EBV 0,5-40/00*		G 1" cyl	-	-	Consult page 116	-	-	KIT EBV 0,5-40/00
10929001925	751052	04557001423						19010401725
EBV 1-40/00*		G 1" cyl	1½" ANSI 150 lbs	1½" ANSI 300 lbs		CE 89	-	KIT EBV 1-40/00
10929101925	751052	04557001423	04542001423	04524101423		20151901220		19044301720
EBV 2,5-40/90		G 1" cyl	1½" ANSI 150 lbs	1½" ANSI 300 lbs		CE 89	-	KIT EBV 2,5-40/90
10929201925	751052	04557001423	04542001423	04524101423		20151901220		19044401720
EBV 5-40/90		G 1" cyl	1½" ANSI 150 lbs	1½" ANSI 300 lbs		CE 89	-	KIT EBV 5-40/90
10929301925	751052	04557001423	04542001423	04524101423		20151901220		19044501725
EBV 10-40/90		G 2" cyl	4" ANSI 150 lbs	4" ANSI 300 lbs		CE 159A		KIT EBV 10-40/90
10910401925	751057	04570301423	04500301423	04520801423		20109001220	10912701200	19043901725
EBV 20-40/90		G 2" cyl	4" ANSI 150 lbs	4" ANSI 300 lbs		CE 159A		KIT EBV 20-40/90
10910501925	751058	04570301423	04500301423	04520801423		20109001220	10912701200	19044001725
EBV 32-40/90		G 2" cyl	4" ANSI 150 lbs	4" ANSI 300 lbs		CE 159A		KIT EBV 32-40/90
10910601925	751059	04570301423	04500301423	04520801423	20109001220	10912701200	19044101725	
EBV 50-40/90		-	4" ANSI 150 lbs	4" ANSI 300 lbs	CE 159A		KIT EBV 50-40/90	
11077501925	751060		04500301423	04520801423	20109001220	10912701200	19044201725	
EBV 100-20/90		-	8" ANSI 150 lbs	8" ANSI 300 lbs	CE 300		KIT EBV 100-20/90	
10951901920	751061		04500801423	04500901423			19044601720	
EBV 200-20/90		-	8" ANSI 150 lbs	8" ANSI 300 lbs	CE 300		KIT EBV 200-20/90	
10952001920	751062		04500801423	04500901423			19044701720	

* according to the PED, article 3.3

Type	Effective Gas vol. Litres	Max. Working pressure (PS) bar	Max Weight kg	Dimensions in mm							
				A max height	B	C	øD max	ød	G connection	øH	
EBV 0,5-40/00*	0,5	40	1.20	246	52	30	91	16	G2"	70	
EBV 1-40/00*	1	40	1.70	312	52	75	110	22.5	G2"	70	
EBV 2,5-40/90	2,5	40	3.50	486	51	75	109.5	22.5	G2"	70	
EBV 5-40/90	5	40	6.50	869	51	75	109.5	22.5	G2"	70	
EBV 10-40/90	10	40	13	454	51	75	212	22.5	G3½"	120	
EBV 20-40/90	18	40	22	774	51	75	212	22.5	G3½"	120	
EBV 32-40/90	34	40	37	1307	51	75	212	22.5	G3½"	120	
EBV 50-40/90	50	40	51	1829	51	75	212	22.5	G3½"	120	
EBV 100-20/90	90	20	92	1317	158	93	371	80	M205 x 3	224	
EBV 200-20/90	207	20	171	2528	158	93	371	80	M205 x 3	224	

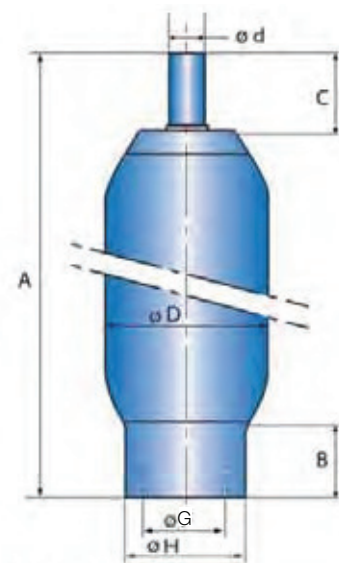

Above dimensions are in mm and are subject to manufacturing tolerances.

Adaptors EBV Carbon Steel

Accumulator model	Connection of accumulator ø F gas cyl.	Connection ø I gas cyl.	Part Number
EBV 0,5 to 5 Litres 50 & 80 Bar	2"	1"	04557000223
		Blind	04502400223
EBV 10 to 50 Litres 40 Bar	3 1/2"	2"	04570300223
		Blind	04500500223
EBV 100 to 200 Litres 40 Bar	M205 x 3	2"	04565600223
		Blind	04500600223

(1) 2 holes dia 8,5 x 10

Adaptors EBV Stainless Steel

Accumulator model	Connection of accumulator ø F gas cyl.	Connection ø I gas cyl.	Part Number
EBV 0,5 to 5 Litres 50 & 80 Bar	2"	1"	04557001423
		Blind	04502401423
EBV 10 to 50 Litres 40 Bar	3 1/2"	2"	04570301423
		Blind	04500501423
EBV 100 to 200 Litres 40 Bar	M205 x 3	2"	04565601423
		Blind	04500601423

(1) 2 holes dia 8,5 x 10

Flanges EBV Carbon Steel

Accumulator model	Connection of accumulator ø G gas cyl.	Flange Model	Part Number	K
EBV 1 to 5 Litres 80 Bar	2"	1 1/2" ANSI 150 lbs	04542000123	22
		1 1/2" ANSI 300 lbs	04524100123	25
EBV 10 to 50 Litres 40 Bar	3 1/2"	4" ANSI 150 lbs	04500300123	28
		4" ANSI 300 lbs	04520800123	37
EBV 100 to 575 Litres 40 Bar	M205 x 3	8" ANSI 150 lbs	04500800123	142
		8" ANSI 300 lbs	04500900123	151

Flanges EBV Stainless Steel

Accumulator model	Connection of accumulator ø G gas cyl.	Flange Model	Part Number	K
EBV 1 to 5 Litres 80 Bar	2"	1 1/2" ANSI 150 lbs	04542001423	22
		1 1/2" ANSI 300 lbs	04524101423	25
EBV 10 to 50 Litres 40 Bar	3 1/2"	4" ANSI 150 lbs	04500301423	28
		4" ANSI 300 lbs	04520801423	37
EBV 100 to 575 Litres 40 Bar	M205 x 3	8" ANSI 150 lbs	04500801423	142
		8" ANSI 300 lbs	04500901423	151

Shape	J/Flats	K	O-ring & Back-up Ring
A	-	13	A. O-Ring 54 x 3
A	65	13	O-Ring 54 x 3
A	112	20	O-Ring 96 x 4
A	112	20	O-Ring 96 x 4
A	-	(1)	O-Ring 196,21 x 5,33
A	-	(1)	O-Ring 196,21 x 5,33

Shape	J/Flats	K	O-ring & Back-up Ring
A	-	13	A. O-Ring 54 x 3
A	65	13	O-Ring 54 x 3
A	112	20	O-Ring 96 x 4
A	112	20	O-Ring 96 x 4
A	-	(1)	O-Ring 196,21 x 5,33
A	-	(1)	O-Ring 196,21 x 5,33

Adaptors EBV

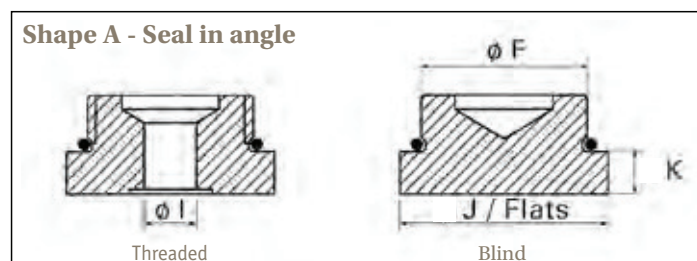

Flanges EBV

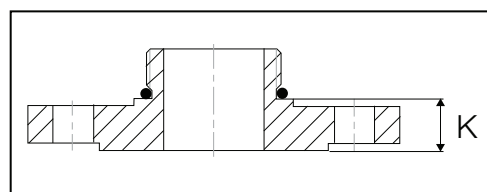

These accessories are designed to perfectly fit Parker Olaer accumulators. They meet the latest regulations and are compliant with the CETOP standard.

ELG and OLG Series, 20 & 50 bar

Standard Version (Steel shell or **Stainless steel**/ NBR mix) for mineral oils temperature from - 15° up to 100°C
 According to PED 97/23/EC, EN 14359 Fluid Group 2

Part numbers, Accessories, Dimensions

Type Part number	Pre-charge	Clamps
	1 - 20 bar	Model (quantity) Part number
OLG 0.13-50/00 (1) 10268401925	751011	-
OLG 1-20/00 (2) 10411901125	751053	E106 (1) 20250903648
ELG 4-20/90 3/4" (3) 10931201925	751055	E155 (1) 20251203648
ELG 4-20/90 2" (3) 10931301925	751055	E155 (1) 20251203648

(1) according to the PED, article 3.3 stainless steel

(2) according to the PED, article 3.3

(3) according to the PED stainless steel

Type	Effective Gas vol. Litres	Max. Working pressure (PS) bar	Weight kg	Gas Connection	Dimensions in mm						
					A max height	B	C	øD max	ø Spot facing x depth	SW	G connection
OLG 0.13-50/00 (1)	0.1	50	0.3	8V1	136	16	13	50	33 x 0.5	6 flats 36 A/F	G ¼" cyl.
OLG 1-20/00 (2)	1	20	1.6	8V1	210	31	11	107	-	2 flats 46 A/F	G 1" cyl.
ELG 4-20/90 3/4" (3)	3.8	20	3.5	8V1	337	28	16	155	73 x 1.5	2 flats 82 A/F	G ¾" cyl.
ELG 4-20/90 2" (3)	3.8	20	3.7	8V1	340	40	16	155	73 x 1.5	2 flats 82 A/F	G 2" cyl.

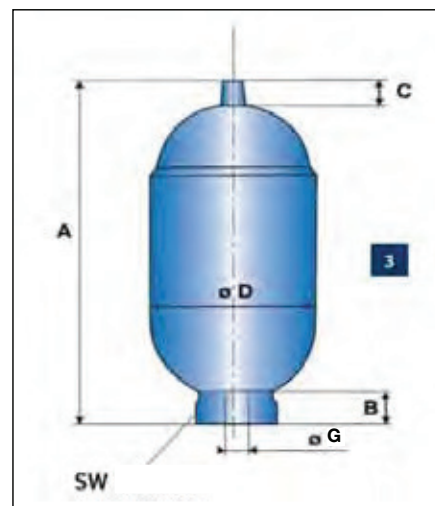
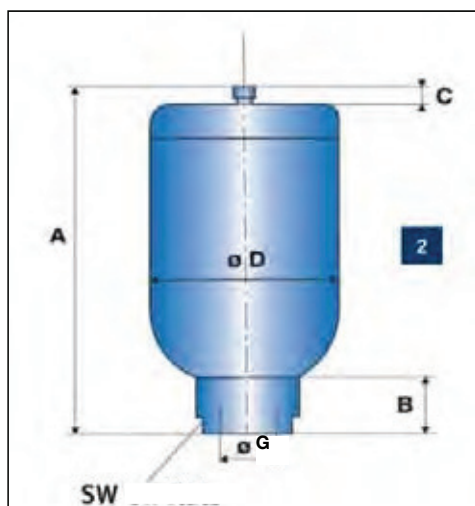
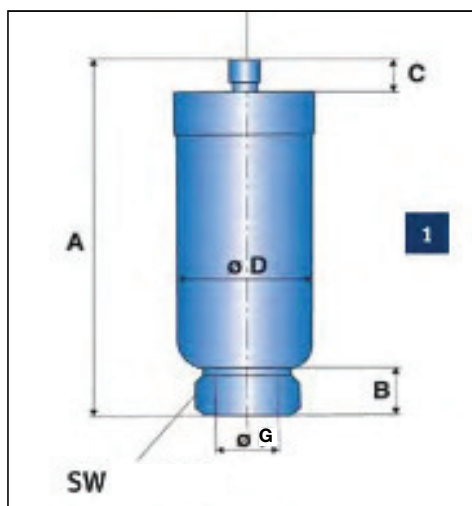

Above dimensions are in mm and are subject to manufacturing tolerances.

EHV Series: General Information Bladder Accumulators

Operation of the OLAER gas loaded bladder accumulator is based on the considerable difference in compressibility between a gas and a liquid, enabling a large quantity of energy to be stored in an extremely compact form. This enables a liquid under pressure to be accumulated, stored and recovered at any time.

Its special design allows the bladder (the strategic component) to compress the gas and usually form into three lobes in order for the accumulator to store, then to deliver the fluid under pressure, as required.

The OLAER gas loaded accumulator is an essential component for the optimum operation of a hydraulic circuit. In hydraulic circuits, the accumulator enables:

- An energy reserve which is instantaneously available to the system
- Compensation of pressure fluctuations and spikes.
- Pump pulsation dampening

The accumulator comprises of a pressure vessel, a rubber bladder and an anti-extrusion system. Shell material options include alloyed steel, stainless steel, aluminium, titanium and composites. Various bladder materials available which are compatible with a range of fluids and temperatures.

Taking into account the different needs of various applications, Olaer proposes different protections external and/or internal: Bare metal, nickel plating, epoxy paint, PTFE, Rilsan® and phenolic coating. This extensive range enables us to offer accumulators operating from - 50 to +150°C with pressures of up to 1500 Bar and capacities of up to 575 litres.

As the market leader in bladder type accumulators, Olaer has participated in the development of the EN 14359:2006 standard, which specifies the material, design, manufacturing, tests, safety devices and documentation (including the instruction manual), for pressure accumulators and gas bottles for hydraulic applications.

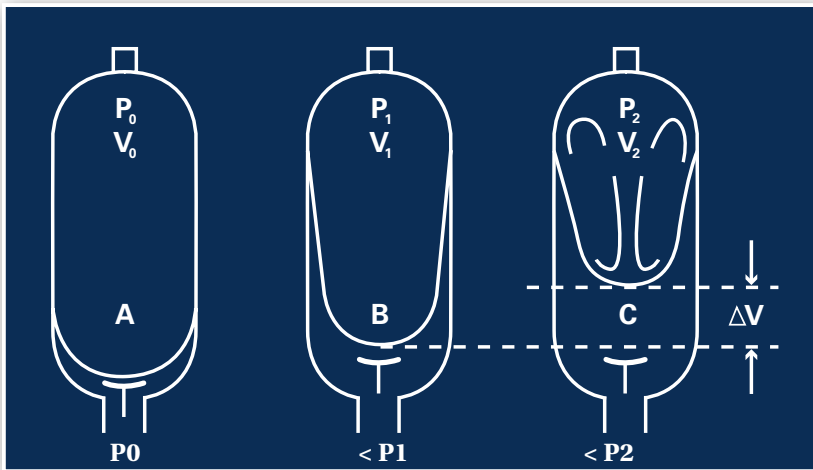

V0 = Capacity in nitrogen of the accumulator
V1 = Gas volume at the minimum hydraulic pressure
V2 = Gas volume at the maximum hydraulic pressure
 ΔV = Returned and/or stored volume of working fluid between P_1 and P_2
P0 = Initial preload of the accumulator
P1 = Gas pressure at the minimum hydraulic pressure
P2 = Gas pressure at the maximum hydraulic pressure

A - Bladder in the Pre-charge position, which means that the accumulator only contains nitrogen. The anti-extrusion system closes the hydraulic orifice which prevents the destruction of the bladder. In low pressure accumulators the bladder rests against the grid.

B - Position at the minimum operating pressure. There must be a certain amount of fluid between the bladder and the hydraulic orifice, such that the anti-extrusion system does not close the hydraulic orifice.

C - Position at the maximum operating pressure. The volume difference between the minimum and maximum positions of the operating pressures represents the working fluid quantity.

EHV Series: How to order a high pressure accumulator

Technical Characteristics

The accumulator comprises a forged steel shell, a rubber bladder and a fluid port assembly.

- Shell material options include alloyed steel, stainless steel, aluminium, titanium and composites.
- Various bladder materials available which are compatible with a range of fluids and temperatures.
- Anti-extrusion system: fluidport assembly for high pressure.

In standard versions : shell in steel, bladder and rings in nitrile for functioning with mineral oils.

Operating temperature : - 20°C + 80°

Special constructions : consult Parker Olaer

Volume from 0.2 to 57 Litres

Pressure from 330 to 690 Bars

Nitrogen gas pressure : The maximum pressure (PS) is indicated on the accumulator. Check that the maximum allowable pressure is greater than that of the hydraulic system.

Others : consult Parker Olaer

Type	+	Part Number (11 characters)	+	Nitrogen Gas Pre-charge	+	Connection to be specified	+	Clamp for fixation	+	Support Bracket	+	Mounting Frame	+	Eye Fit	Part number
<i>Example</i> EHV 32 - 330 / 90		10837301125		P0 = 200b		G 1"		D226 X 2		CE 300		EF1			
Series EHV: High pressure bladder accumulator EHVF: EHV with Flange EHVDA: High Flow EHV ETHV: Transfer type EHV															
Volume in Litres															
Max. working Pressure (PS) in bar															
Regulation Code 00 : According to the PED article 3.3 for the volumes from 0.2 to 1L , Fluid Group 2 90 : According to the PED Others: consult the table pages 58 & 59															
Part Number: 6 characters															
Construction: 1 character 0 : All ranges except transfer 3 : Transfer range 5 : Transfer stainless steel range															
Shell Construction: 2 characters 11 : In carbon steel 19 : Stainless steel, usable for ATEX Others: consult the table page 60															
Bladder Mix: 2 characters 20 : Accumulators > 100L NBR NITRILE STANDARD 25 : Standard construction NBR NITRILE STANDARD Other mixes: Consult the table page 61															
Nitrogen gas Pressure Without specification: Accumulators will be delivered with a storage pressure between 2 and 5 bar. With specification: in specified bar at 20 °C															
Connection to be specified															
Clamp Specify model X quantity															
Support Bracket Specify model															
Mounting Frame Specify model															
Lifting Eye Proposal for easy handling															

EHV Series 330 bar, 10 to 57 Litres

Standard version (**Carbon Steel** shell/NBR mix) for mineral oils temperature from - 20° up to 80°C
 According to PED 97/23/EC, EN 14359 Fluid Group 2
Part numbers, Accessories, Dimensions

Type Part number	Valve model see drawing	Pre-charge			Adaptor* Threaded Part number	Clamps Model (quantity) Part number	Support Bracket Model Part number	Mounting Frame Model Part number	Lifting Eye on gas side Model Part number	Complete Repair Kit Model Part number
		1 - 109 bar	110 - 209 bar	210 - 300 bar						
EHV 10-330/90 10837001125 10865401125	A B	751016	751023	751038	G 1" cyl 04557000223	D226 (2) 20251503648	CE159A 20109003620	EF2 20217600125	10912700200	KIT EHV 10-330/90 19028900225 19035800225
EHV 12-330/90 10867101125 10867401125	A B	751016	751023	751038	G 1" cyl 04557000223	D226 (2) 20251503648	CE159A 20109003620	EF2 20217600125	10912700200	KIT EHV 12-330/90 19032100225 19035900225
EHV 20-330/90 10837101125 10865501125	A B	751005	751024	751039	G 1" cyl 04557000223	D226 (2) 20251503648	CE159A 20109003620	EF2 20217600125	10912700200	KIT EHV 20-330/90 19029000225 19036000225
EHV 24.5-330/90 10837201125 10865601125	A B	751017	751025	751040	G 1" cyl 04557000223	D226 (2) 20251503648	CE159A 20109003620	EF2 20217600125	10912700200	KIT EHV 24.5-330/90 19029400225 19036300225
EHV 32-330/90 10837301125 10865701125	A B	751006	751026	751041	G 1" cyl 04557000223	D226 (2) 20251503648	CE159A 20109003620	EF3 20217700125	10912700200	KIT EHV 32-330/90 19029100225 19036100225
EHV 42-330/90 11112301125 11123601125	A B	751212	751213	751214	G 1" cyl 04557000223	D226 (2) 20251503648	CE159A 20109003620	EF3 20217700125	10912700200	KIT EHV 42-330/90 19060800225 19061100225
EHV 50-330/90 11076701125 11076801125	A B	751007	751027	751042	G 1" cyl 04557000223	D226 (2) 20251503648	CE159A 20109003620	EF3 20217700125	10912700200	KIT EHV 50-330/90 19054100225 19054200225
EHV 57-330/90 11112401125 11123801125	A B	751215	751216	751217	G 1" cyl 04557000223	D226 (2) 20251503648	CE159A 20109003620	EF3 20217700125	10912700200	KIT EHV 57-330/90 19060900225 19061200225

* For more adaptor options see pages 56 & 57.

Model of valve stem
5/8" 18 UNF
(A)



Model of valve stem
7/8" 14 UNF
(B)



Type	Effective Gas vol. Litres	Max. Working pressure (PS) bar	Max Flow Rate l/min	Weight kg	Gas connection	Dimensions in mm							
						A max height	B	C	øD max	ød	øE	F on flats	G connection
EHV 10-330/90	9.2	330	900	31	5/8" 18 UNF	587	103	66	226	22.5	101	70	G 2"
					7/8" 14 UNF								
EHV 12-330/90	11	330	900	36	5/8" 18 UNF	687	103	66	226	22.5	101	70	G 2"
					7/8" 14 UNF								
EHV 20-330/90	17.8	330	900	49	5/8" 18 UNF	897	103	66	226	22.5	101	70	G 2"
					7/8" 14 UNF								
EHV 24.5-330/90	22.5	330	900	56	5/8" 18 UNF	1032	103	66	226	22.5	101	70	G 2"
					7/8" 14 UNF								
EHV 32-330/90	32	330	900	81	5/8" 18 UNF	1420	103	66	226	22.5	101	70	G 2"
					7/8" 14 UNF								
EHV 42-330/90	42	330	900	87	5/8" 18 UNF	1562	103	66	226	22.5	101	70	G 2"
					7/8" 14 UNF								
EHV 50-330/90	48.5	330	900	110	5/8" 18 UNF	1936	103	66	226	22.5	101	70	G 2"
					7/8" 14 UNF								
EHV 57-330/90	53	330	900	116	5/8" 18 UNF	2032	103	66	226	22.5	101	70	G 2"
					7/8" 14 UNF								

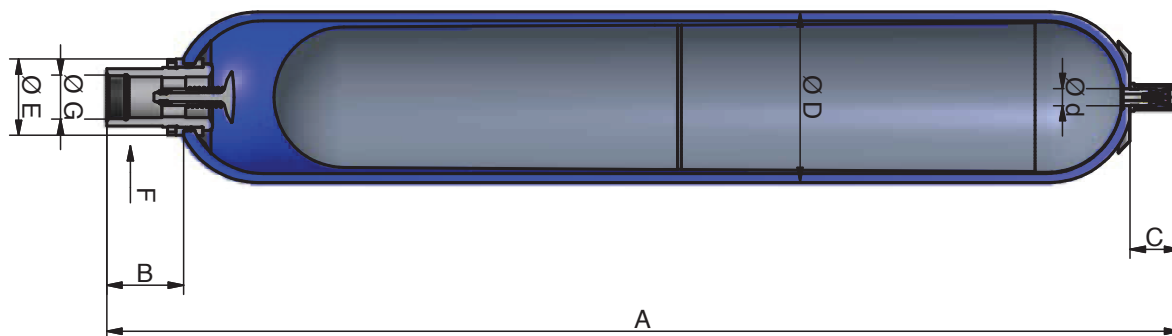

Above dimensions are in mm and are subject to manufacturing tolerances.

EHV Series 350 bar, 0.2 to 10 Litres

Standard Version (**Carbon Steel** shell/NBR mix) for mineral oils temperature from - 20° up to 80°C
 According to PED 97/23/EC, EN 14359 Fluid Group 2
Part numbers, Accessories, Dimensions

Type Part number	Valve model see drawing	Pre-charge			Adaptor** Threaded Part number	Clamps Model (quantity) Part number	Support Bracket Model Part number	Mounting Frame Model Part number	Lifting Eye on gas side Model Part number	Complete Repair Kit Model Part number
		1 - 109 bar	110 - 209 bar	210 - 300 bar						
EHV 0.2-350/00* 10876301120	D	751013	751028	751043	G 1/4" cyl 04556500223	A56 (1) 20149203625	-	-	-	KIT EHV 0.2-350/00 19001000220
EHV 0.5-350/00* 10876401125	D	751000	751029	751044	G 3/8" cyl 04556400223	E95 (1) 20250803648	-	-	-	KIT EHV 0.5-350/00 19001100225
EHV 1-350/00* 10845601125	C	751001	751030	751045	G 3/8" cyl 04556400223	E114 (1) 20251003648	CE 89 20151903620	-	-	KIT EHV 1-350/00 19029700225
10866901125	B									19036400225
EHV 1.6-350/90 10998301125	C	751014	751019	751034	G 3/8" cyl 04556400223	E114 (1) 20251003648	CE 89 20151903620	-	-	KIT EHV 1.6-350/90 19060700225
11123501125	B									19061000225
EHV 2.5-350/90 10854701125	C	751002	751031	751046	G 3/4" cyl 04555200223	E114 (2) 20251003648	CE 89 20151903620	-	-	KIT EHV 2.5-350/90 19029800225
10866601125	B									19036500225
EHV 4-350/90 10845401125	C	751012	751020	751035	G 3/4" cyl 04555200223	E168 (1) 20251303648	CE108 20118703620	EF1 20217500125	-	KIT EHV 4-350/90 19029900225
10866101125	B									19036600225
EHV 5-350/90 10861201125	C	751003	751032	751047	G 3/4" cyl 04555200223	E114 (2) 20251003648	CE 89 20151903620	-	-	KIT EHV 5-350/90 19030000225
10866701125	B									19036700225
EHV 6-350/90 10857401125	C	751015	751021	751036	G 3/4" cyl 04555200223	E168 (2) 20251303648	CE108 20118703620	EF1 20217500125	-	KIT EHV 6-350/90 19030100225
10866201125	B									19036800225
EHV 10-350/90 10859701125	C	751004	751022	751037	G 3/4" cyl 04555200223	E168 (2) 20251303648	CE108 20118703620	EF1 20217500125	10912700200	KIT EHV 10-350/90 19030200225
10866301125	B									19036900225

* according to the PED, article 3.3

** For more adaptor options see pages 56 & 57.

Model of valve stem
7/8" 14 UNF
(B)



Model of valve stem
7/8" 14 UNF
(C)

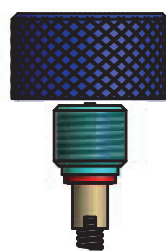

Model of valve stem
5/8" 18 UNF
(D)



Type	Effective Gas vol. Litres	Max. Working pressure (PS) bar	Max Flow Rate l/min	Weight kg	Gas connection	Dimensions in mm								G connection
						A max height	B	C	øD max	ød	øE	F on flats		
EHV 0.2-350/00	0.2	350	120	2.5	5/8" 18 UNF	268	38	27	58	16	39	24	G 1/2"	
EHV 0.5-350/00	0.6	350	240	2.7	5/8" 18 UNF	259	54	28	91	16	50	32	G 3/4"	
EHV 1-350/00	1	350	240	6	7/8" 14 UNF	330	54	66	116	22.5	50	32	G 3/4"	
					7/8" 14 UNF									
EHV 1.6-350/90	1.6	350	240	8	7/8" 14 UNF	442	54	66	116	22.5	50	32	G 3/4"	
					7/8" 14 UNF									
EHV 2.5-350/90	2.4	350	450	11	7/8" 14 UNF	549	66	66	116	22.5	68	50	G 1 1/4"	
					7/8" 14 UNF									
EHV 4-350/90	3.7	350	450	15	7/8" 14 UNF	434	65	66	170	22.5	68	50	G 1 1/4"	
					7/8" 14 UNF									
EHV 5-350/90	5	350	450	17	7/8" 14 UNF	898	66	66	116	22.5	68	50	G 1 1/4"	
					7/8" 14 UNF									
EHV 6-350/90	6	350	450	20	7/8" 14 UNF	560	65	66	170	22.5	68	50	G 1 1/4"	
					7/8" 14 UNF									
EHV 10-350/90	10	350	450	31	7/8" 14 UNF	825	65	66	170	22.5	68	50	G 1 1/4"	
					7/8" 14 UNF									

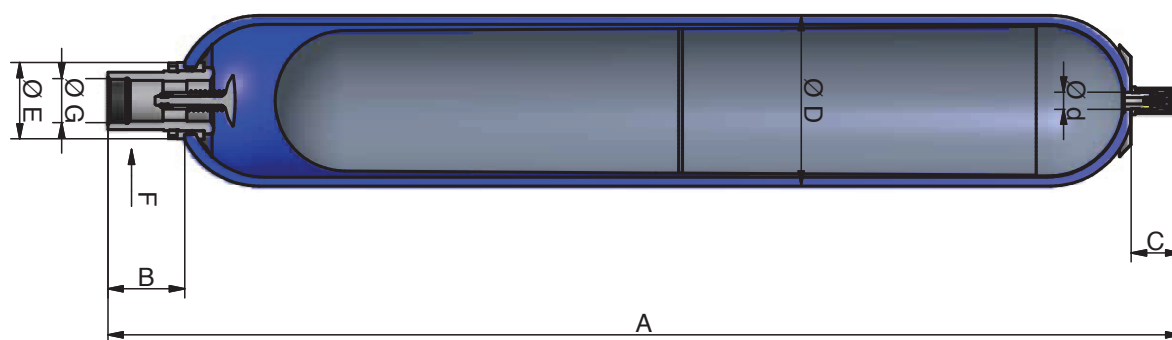

Above dimensions are in mm and are subject to manufacturing tolerances.

EHV Series 480 bar, 10 to 50 Litres

Standard Version (**Carbon Steel** shell/NBR mix) for mineral oils temperature from - 20° up to 80°C
 According to PED 97/23/EC, EN 14359 Fluid Group 2
Part numbers, Accessories, Dimensions

Type	Pre-charge			Adaptor*	Clamps	Support Bracket	Mounting Frame	Lifting Eye on gas side	Complete Repair Kit
	1 - 109 bar	110 - 209 bar	210 - 300 bar						
EHV 10-480/90 10949901125	751016	751023	751038	G 1" cyl 04557000223	D226 (2) 20251503648	CE159A 20109003620	EF2 20217600125	10912700200	KIT EHV 10-480/90 19055702525
EHV 12-480/90 10950001125	751016	751023	751038	G 1" cyl 04557000223	D226 (2) 20251503648	CE159A 20109003620	EF2 20217600125	10912700200	KIT EHV 12-480/90 19063002525
EHV 20-480/90 10950101125	751005	751024	751039	G 1" cyl 04557000223	D226 (2) 20251503648	CE159A 20109003620	EF2 20217600125	10912700200	KIT EHV 20-480/90 19050002525
EHV 32-480/90 10950201125	751006	751026	751041	G 1" cyl 04557000223	D226 (2) 20251503648	CE159A 20109003620	EF3 20217700125	10912700200	KIT EHV 32-480/90 19051302525
EHV 50-480/90 10950301125	751007	751027	751042	G 1" cyl 04557000223	D226 (2) 20251503648	CE159A 20109003620	EF3 20217700125	09098800200	KIT EHV 50-480/90 19050302525

* For more adaptor options see page 56 & 57.

Model of valve stem
 7/8" 14 UNF
 (E)

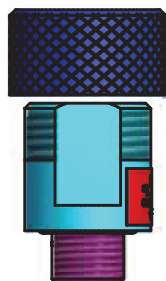

Type	Effective Gas vol. Litres	Max. Working pressure (PS) bar	Max Flow Rate l/min	Weight kg	Gas connection	Dimensions in mm							
						A max height	B	C	øD max	ød	øE	F on flats	G connection
EHV 10-480/90	9.2	480	900	33	7/8" 14 UNF	593	103	74	228	22.5	101	70	G 2"
EHV 12-480/90	11	480	900	43	7/8" 14 UNF	693	103	74	228	22.5	101	70	G 2"
EHV 20-480/90	17.8	480	900	63	7/8" 14 UNF	903	103	74	228	22.5	101	70	G 2"
EHV 32-480/90	32	480	900	97	7/8" 14 UNF	1428	103	74	228	22.5	101	70	G 2"
EHV 50-480/90	48.5	480	900	132	7/8" 14 UNF	1968	103	99	228	50	101	70	G 2"

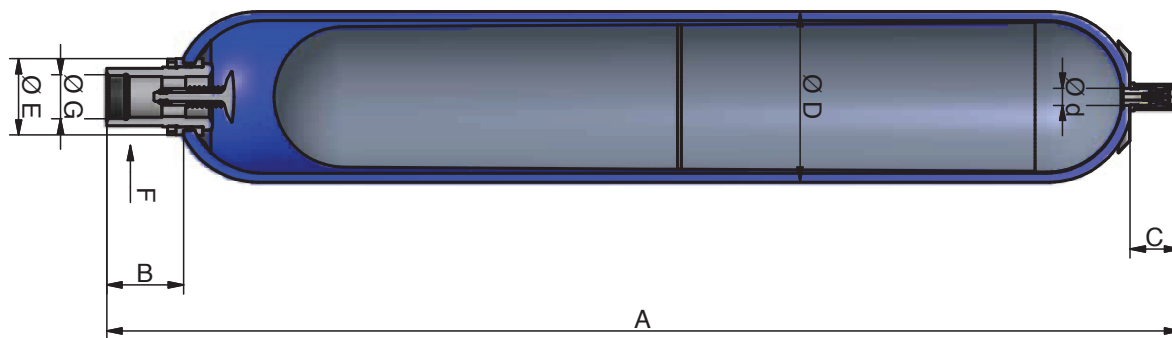

Above dimensions are in mm and are subject to manufacturing tolerances.

EHV Series 690 bar, 1 to 54 Litres

Standard Version (**Carbon Steel** shell/NBR mix) for mineral oils temperature from - 20° up to 80°C
 According to PED 97/23, EN 14359 Fluid Group 2
Part numbers, Accessories, Dimensions

Type	Pre-charge			Adaptor**	Clamps	Support Bracket	Lifting Eye on gas side	Complete Repair Kit
	1 - 109 bar	110 - 209 bar	210 - 300 bar					
Part number				Threaded Part number	Model (quantity) Part number	Model Part number	Model Part number	Model Part number
EHV 1-690/00*				G 1/2" cyl	E114 (1)	CE89		KIT EHV 1- 690/00
10910101125	751001	751030	751045	04570400223	20251003648	20151903620	10912700200	19043500225
EHV 2.5-690/90				G 1/2" cyl	E114 (2)	CE89		KIT EHV 2.5-690/90
10910201125	751002	751031	751046	04570400223	20251003648	20151903620	10912700200	19043600225
EHV 5-690/90				G 1/2" cyl	E114 (2)	CE89		KIT EHV 5-690/90
10910301125	751003	751032	751047	04570400223	20251003648	20151903620	10912700200	19043700225

* according to the PED, article 3.3

** For more adaptor options see pages 56 & 57.

EHV 690 bar

Type	Pre-charge			Adaptor	Clamps	Support Bracket	Complete Repair Kit
	1 - 109 bar	110 - 209 bar	210 - 300 bar				
Part number				Threaded Part number	Model (quantity) Part number	Model Part number	Model Part number
EHV 12-690/90	Consult Division			Consult Division	Consult Division	Consult Division	KIT EHV 12-690/90
1203V-DC-691	751016	751023	751038				KIT EHV 20-690/90
EHV 20-690/90	Consult Division						KIT EHV 32-690/90
2003V-DC-691	751005	751024	751039				KIT EHV 54-690/90
EHV 37-690/90	Consult Division						
3703V-DC-691	751006	751026	751041				
EHV 54-690/90	Consult Division						
5003V-DC-691	751007	751027	751042				

Model of valve stem
 7/8" 14 UNF
 (E)

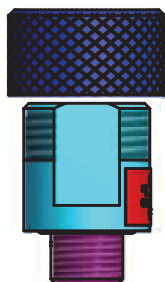

Accumulators are delivered with the nitrogen Pre-charge 3 bar.

Type	Effective Gas vol. Litres	Max. Working pressure (PS) bar	Max Flow Rate l/min	Weight kg	Dimensions in mm								
					A max height	B	C	øD max	ød	øE	F on flats	G connection**	
EHV 1-690/00*	1.1	690	360	8.9	376	68	69	122	22.5	68	45	G 1"	
EHV 2.5-690/90	2.4	690	360	15	551	68	69	122	22.5	68	45	G 1"	
EHV 5-690/90	5	690	360	29	900	68	69	122	22.5	68	45	G 1"	

** Requires a special adaptor

Type	Effective Gas vol. Litres	Max. Working pressure (PS) bar	Max Flow Rate l/min	Weight kg	Dimensions in mm								
					A max height	B	C	øD max	ød	øE	F on flats	G connection**	
EHV 12-690/90	11	690	900	97	682	84	166	267	50	110	77	2"	
EHV 20-690/90	16.5	690	900	134	892	84	166	267	50	110	77	2"	
EHV 37-690/90	33.4	690	900	227	1417	84	166	267	50	110	77	2"	
EHV 54-690/90	48	690	900	318	1932	84	166	267	50	110	77	2"	

** Requires a special adaptor

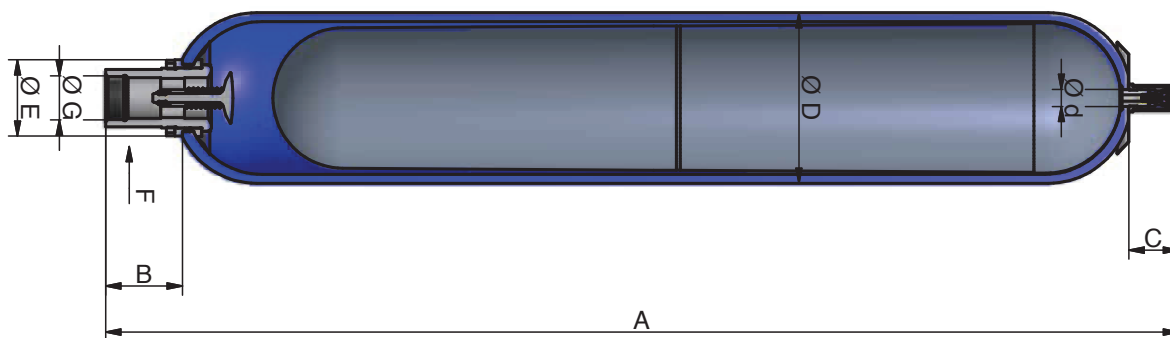

Above dimensions are in mm and are subject to manufacturing tolerances.

EHVF Series 330 bar, 10 to 57 Litres

Flanged Fluid Port

Standard Version (**Carbon Steel** shell/NBR mix) for mineral oils temperature from - 20° up to 80°C
 According to PED 97/23/EC, EN 14359 Fluid Group 2
Part numbers, Accessories, Dimensions

Type Part number	Pre-charge			Flange*	Clamps	Support Bracket	Mounting Frame	Lifting Eye on gas side	Complete Repair Kit
	1 - 109 bar	110 - 209 bar	210 - 300 bar	Type Part number	Model (quantity) Part number	Model Part number	Model Part number	Model Part number	Model Part number
EHVF 10-330/90 10844901125	751016	751023	751038	BR 400-38 35132400123	D226 (2) 20251503648	CE 159A 20109003620	EF2 20217600125		KIT EHVF 10-330/90 19034600225
EHVF 12-330/90 10867301125	751016	751023	751038	BR 400-38 35132400123	D226 (2) 20251503648	CE 159A 20109003620	EF2 20217600125		KIT EHVF 12-330/90 19034700225
EHVF 20-330/90 10845001125	751005	751024	751039	BR 400-38 35132400123	D226 (2) 20251503648	CE 159A 20109003620	EF2 20217600125		KIT EHVF 20-330/90 19034800225
EHVF24.5-330/90 10845101125	751017	751025	751040	BR 400-38 35132400123	D226 (2) 20251503648	CE 159A 20109003620	EF2 20217600125		KIT EHVF 24.5-330/90 19035100225
EHVF 32-330/90 10845201125	751006	751026	751041	BR 400-38 35132400123	D226 (2) 20251503648	CE 159A 20109003620	EF3 20217700125		KIT EHVF 32-330/90 19034900225
EHVF 42-330/90 11132501125	751212	751213	751214	BR 400-38 35132400123	D226 (2) 20251503648	CE 159A 20109003620	EF3 20217700125		KIT EHVF 50-330/90 19062200225
EHVF 50-330/90 11077001125	751007	751027	751042	BR 400-38 35132400123	D226 (2) 20251503648	CE 159A 20109003620	EF3 20217700125		KIT EHVF 50-330/90 19054400225
EHVF 57-330/90 11132601125	751215	751216	751217	BR 400-38 35132400123	D226 (2) 20251503648	CE 159A 20109003620	EF3 20217700125		KIT EHVF 57-330/90 19062300225

* For more adaptor options see page 56 & 57.

Model of valve stem
 5/8" 18 UNF
 (A)



Accumulators are delivered with the nitrogen Pre-charge 3 bar.

Type	Effective Gas vol. Litres	Max. Working pressure (PS) bar	Max Flow Rate l/min	Weight kg	Gas connection	Dimensions in mm									
						A max height	B	C	øD max	ød	øE	øG connection	F on flats	øL	M
EHVF 10-330/90	9.2	330	900	31	5/8"18 UNF	627	143	66	226	22.5	101	34	70	63.8	12.5
EHVF 12-330/90	11	330	900	36	5/8"18 UNF	727	143	66	226	22.5	101	34	70	63.8	12.5
EHVF 20-330/90	17.8	330	900	49	5/8"18 UNF	937	143	66	226	22.5	101	34	70	63.8	12.5
EHVF24.5-330/90	22.5	330	900	56	5/8"18 UNF	1072	143	66	226	22.5	101	34	70	63.8	12.5
EHVF 32-330/90	32	330	900	81	5/8"18 UNF	1460	143	66	226	22.5	101	34	70	63.8	12.5
EHVF 42-330/90	42	330	900	87	5/8"18 UNF	1602	143	66	226	22.5	101	34	70	63.8	12.5
EHVF 50-330/90	48.5	330	900	110	5/8"18 UNF	1976	143	66	226	22.5	101	34	70	63.8	12.5
EHVF 57-330/90	53	330	900	116	5/8"18 UNF	2072	143	66	226	22.5	101	34	70	63.8	12.5

Note: Connection (norme ISO 6162): 1 1/2" SAE 6000 PSI.

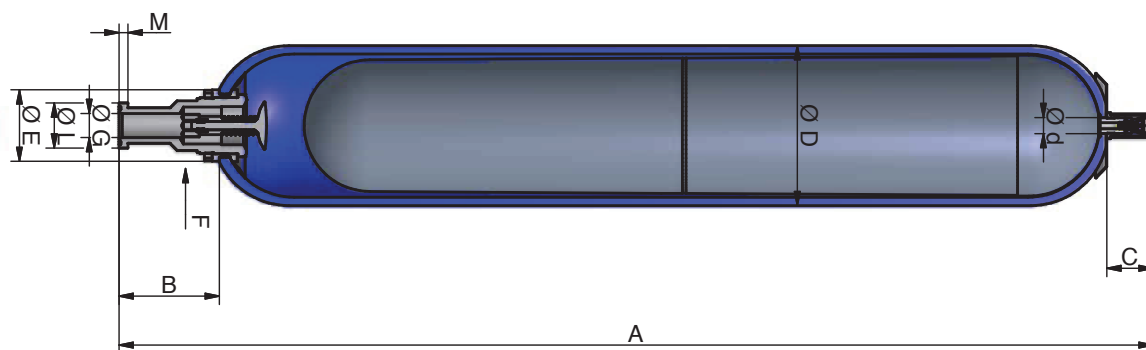

Above dimensions are in mm and are subject to manufacturing tolerances.

EHVF Series 350 bar, 2.5 to 10 Litres Flanged Fluid Port

Standard Version (**Carbon Steel** shell/NBR mix) for mineral oils temperature from - 20° up to 80°C
 According to PED 97/23/EC, EN 14359 Fluid Group 2
Part numbers, Accessories, Dimensions

Type Part number	Pre-charge			Flange*	Clamps	Support Bracket	Mounting Frame	Lifting Eye on gas side	Complete Repair Kit
	1 - 109 bar	110 - 209 bar	210 - 300 bar	Type Part number	Model (quantity) Part number	Model Part number	Model Part number	Model Part number	Model Part number
EHVF 2.5-350/90 10861501125	751002	751031	751046	BR 400-25 35132600123	E114 (2) 20251003648	CE89 20151903620	-	10912700200	KIT EHVF 2.5-350/90 19035300225
EHVF 4-350/90 10857601125	751012	751020	751035	BR 400-25 35132600123	E168 (1) 20251303648	CE108 20118703620	EF1 20217500125	10912700200	KIT EHVF 4-350/90 19035400225
EHVF 5-350/90 10861601125	751003	751032	751047	BR 400-25 35132600123	E114 (2) 20251003648	CE89 20151903620	-	10912700200	KIT EHVF 5-350/90 19035500225
EHVF 6-350/90 10857701125	751015	751021	751036	BR 400-25 35132600123	E168 (1) 20251303648	CE108 20118703620	EF1 20217500125	10912700200	KIT EHVF 6-350/90 19035600225
EHVF 10-350/90 10859901125	751004	751022	751037	BR 400-25 35132600123	E168 (2) 20251303648	CE108 20118703620	EF1 20217500125	10912700200	KIT EHVF 10-350/90 19035700225

* For more adaptor options see page 56 & 57.

Model of valve stem
 7/8"14 UNF
 (C)

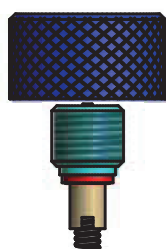

Type	Effective Gas vol. Litres	Max. Working pressure (PS) bar	Max Flow Rate l/min	Weight kg	Gas connection	Dimensions in mm									
						A max height	B	C	øD max	ød	øE	F on flats	øG	øL Max	M
EHVF 2.5-350/90	2.4	350	450	11	7/8" 14 UNF	595	111	66	116	22.5	68	50	22	47.9	9.5
EHVF 4-350/90	3.7	350	450	15	7/8" 14 UNF	480	110	66	170	22.5	68	50	22	47.9	9.5
EHVF 5-350/90	5	350	450	17	7/8" 14 UNF	944	111	66	116	22.5	68	50	22	47.9	9.5
EHVF 6-350/90	6	350	450	20	7/8" 14 UNF	606	110	66	170	22.5	68	50	22	47.9	9.5
EHVF 10-350/90	10	350	450	31	7/8" 14 UNF	871	110	66	170	22.5	68	50	22	47.9	9.5

Note: Connection (norme ISO 6162): 1" SAE 6000 PSI.

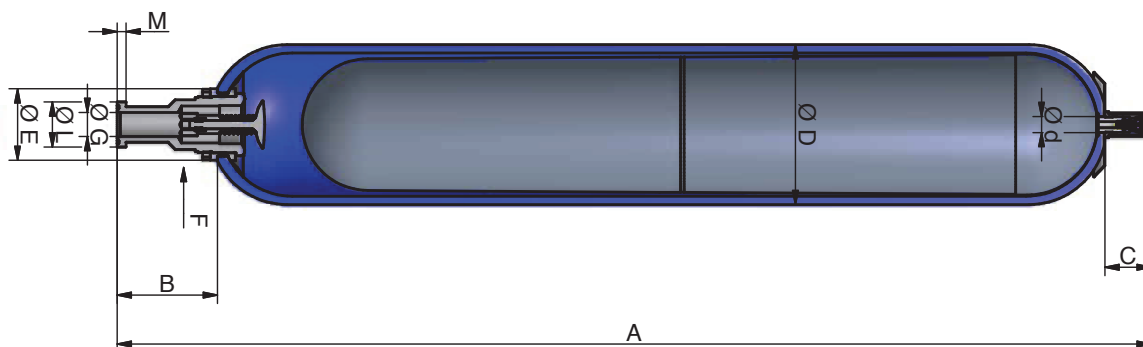

Above dimensions are in mm and are subject to manufacturing tolerances.

EHV-DA Series 330 bar, 10 to 57 Litres

High Flow fluid port, 1200 l/min

Standard version (**Carbon Steel** shell/NBR mix) for mineral oils temperature from - 20° up to 80°C
 For high flow (up to 1200 Litres/min), According to PED 97/23/EC, EN 14359 Fluid Group 2
Part numbers, Accessories, Dimensions

Type Part number	Pre-charge			Adaptor*	Clamps	Support Bracket	Mounting Frame	Lifting Eye on gas side	Complete Repair Kit
	1 - 109 bar	110 - 209 bar	210 - 300 bar	Threaded Part number	Model (quantity) Part number	Model Part number	Model Part number	Model Part number	Model Part number
EHV 10-330/90/DA 10874801125	751016	751023	751038	G 1" cyl 04557000223	D226 (2) 20251503648	CE 159A 20109003620	EF2 20217600125	10912700200	KIT EHV 10-330/90 19028900225
EHV 12-330/90/DA 10874901125	751016	751023	751038	G 1" cyl 04557000223	D226 (2) 20251503648	CE 159A 20109003620	EF2 20217600125	10912700200	KIT EHV 12- 330/90 19032100225
EHV 20-330/90/DA 10846301125	751005	751024	751039	G 1" cyl 04557000223	D226 (2) 20251503648	CE 159A 20109003620	EF2 20217600125	10912700200	KIT EHV 20- 330/90 19029000225
EHV 24.5-330/90/DA 10875001125	751017	751025	751040	G 1" cyl 04557000223	D226 (2) 20251503648	CE 159A 20109003620	EF2 20217600125	10912700200	KIT EHV 24.5-330/90 19029400225
EHV 32-330/90/DA 10846501125	751006	751026	751041	G 1" cyl 04557000223	D226 (2) 20251503648	CE 159A 20109003620	EF3 20217700125	10912700200	KIT EHV 32-330/90 19029100225
EHV 42-330/90/DA 11145201125	751212	751213	751214	G 1" cyl 04557000223	D226 (2) 20251503648	CE 159A 20109003620	EF3 20217700125	10912700200	KIT EHV 42-330/90 19060800225
EHV 50-330/90/DA 11091501125	751007	751027	751042	G 1" cyl 04557000223	D226 (2) 20251503648	CE 159A 20109003620	EF3 20217700125	10912700200	KIT EHV 50-330/90 19054100225
EHV 57-330/90/DA 11145401125	751215	751216	751217	G 1" cyl 04557000223	D226 (2) 20251503648	CE 159A 20109003620	EF3 20217700125	10912700200	KIT EHV 57-330/90 19060900225

* For more adaptor options see pages 56 & 57.

Model of valve stem
 5/8" 18 UNF
 (A)



Type	Effective Gas vol. Litres	Max. Working pressure (PS) bar	Max Flow Rate l/min	Max Weight kg	Gas Connection	Dimensions in mm							
						A max height	B	C	øD max	ød	øE	øG connection	F on flats
EHV 10-330/90/DA	9.2	330	1200	31	5/8"18 UNF	587	103	66	226	22.5	101	G 2"	70
EHV 12-330/90/DA	11	330	1200	36	5/8"18 UNF	687	103	66	226	22.5	101	G 2"	70
EHV 20-330/90/DA	17.8	330	1200	49	5/8"18 UNF	897	103	66	226	22.5	101	G 2"	70
EHV 24.5-330/90/DA	22.5	330	1200	56	5/8"18 UNF	1032	103	66	226	22.5	101	G 2"	70
EHV 32-330/90/DA	32	330	1200	81	5/8"18 UNF	1420	103	66	226	22.5	101	G 2"	70
EHV 42-330/90/DA	42	330	1200	87	5/8"18 UNF	1562	103	66	226	22.5	101	G 2"	70
EHV 50-330/90/DA	48.5	330	1200	110	5/8"18 UNF	1936	103	66	226	22.5	101	G 2"	70
EHV 57-330/90/DA	53	330	1200	116	5/8"18 UNF	2032	103	66	226	22.5	101	G 2"	70

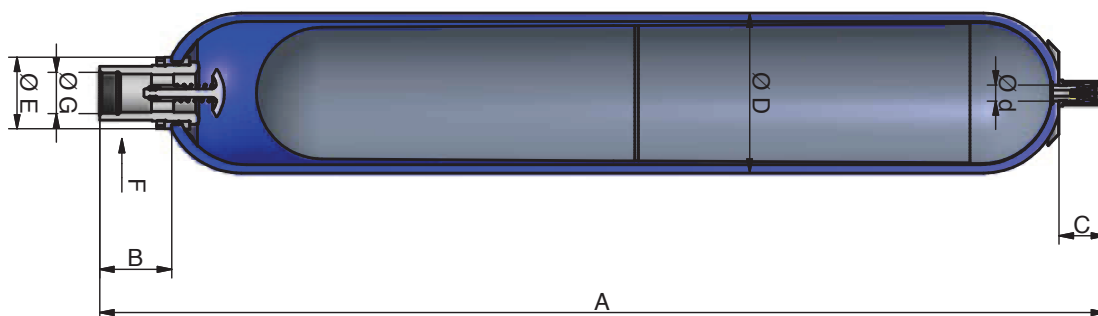

Above dimensions are in mm and are subject to manufacturing tolerances.

EHV-DA Series 350 bar, 2.5 to 10 Litres

High Flow fluid port, 570 l/min

Standard Version (**Carbon Steel** shell/NBR mix) for mineral oils temperature from - 20° up to 80°C
 For high flow (up to 570 Litres/min), According to PED 97/23/CE, EN 14359 Fluid Group 2
Part numbers, Accessories, Dimensions

Type Part number	Pre-charge			Adaptor*	Clamps	Support Bracket	Mounting Frame	Lifting Eye	Complete Repair Kit
	1 - 109 bar	110 - 209 bar	210 - 300 bar	Threaded Part number	Model (quantity) Part number	Model Part number	Model Part number	Model Part number	Model Part number
EHV 2.5-350/90/DA 10846101125	751002	751031	751046	G 3/4" cyl 04555200223	E114 (2) 20251003648	CE 89 20151903620	-	-	KIT EHV 2.5-350/90 19029800225
EHV 4-350/90/DA 10846701125	751012	751020	751035	G 3/4" cyl 04555200223	E168 (2) 20251303648	CE108 20118703620	EF1 20217500125	-	KIT EHV 4-350/90 19029900225
EHV 5-350/90/DA 10874601125	751003	751032	751047	G 3/4" cyl 04555200223	E114 (2) 20251003648	CE 89 20151903620	-	-	KIT EHV 5-350/90 19030000225
EHV 6-350/90/DA 10874701125	751015	751021	751036	G 3/4" cyl 04555200223	E168 (2) 20251303648	CE108 20118703620	EF1 20217500125	-	KIT EHV 6-350/90 19030100225
EHV 10-350/90/DA 10845901125	751004	751022	751037	G 3/4" cyl 04555200223	E168 (2) 20251303648	CE108 20118703620	EF1 20217500125	10912700200	KIT EHV 10- 350/90 19030200225

* For more adaptor options see pages 56 & 57.

Model of valve stem
 7/8"14 UNF
 (C)

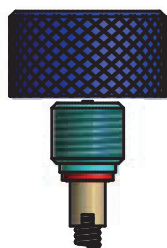

Type	Effective Gas vol. Litres	Max. Working pressure (PS) bar	Max Flow Rate lt/min	Max Weight kg	Gas connection	Dimensions in mm							
						A max height	B	C	øD max	ød	øE	øG connection	F on flats
EHV 2.5-350/90/DA	2.4	350	570	11	7/8" 14 UNF	548	66	66	115	22.5	68	G 1¼"	50
EHV 4-350/90/DA	3.7	350	570	15	7/8" 14 UNF	433	65	66	170	22.5	68	G 1¼"	50
EHV 5-350/90/DA	5	350	570	17	7/8" 14 UNF	897	66	66	115	22.5	68	G 1¼"	50
EHV 6-350/90/DA	6	350	570	20	7/8" 14 UNF	559	65	66	170	22.5	68	G 1¼"	50
EHV 10-350/90/DA	10	350	570	31	7/8" 14 UNF	824	65	66	170	22.5	68	G 1¼"	50

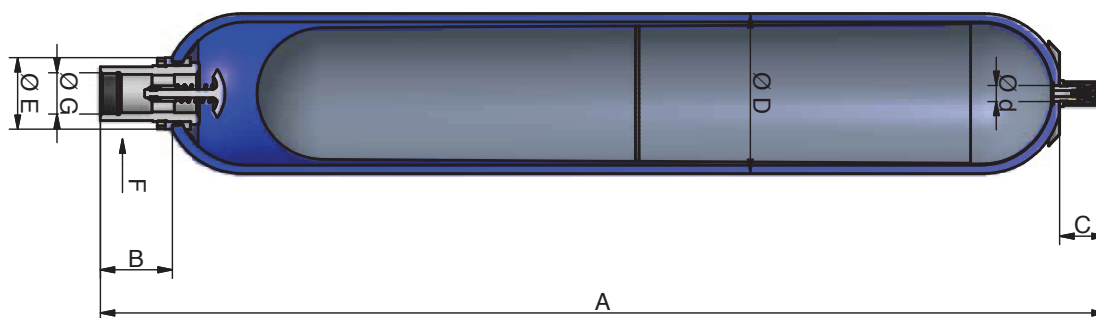

Above dimensions are in mm and are subject to manufacturing tolerances.

EHV Series 70 bar, 10 to 50 Litres

Standard version (**Stainless Steel** shell/bladder for mineral oils) temperature from - 20° up to 100°C

According to PED 97/23/EC, Fluid Group 1/2

Part numbers, Accessories, Dimensions

Type	Part number	Adaptor	Flanges	Clamps	Support Bracket	Complete Repair Kit
				Model (quantity)	Model	Part number
				Part number	Part number	
EHV 10.70/90	JN301007052CXR25	Various adaptors and flanges available		D226 (2)	CE159A	8590018-xyyy
	JN30100705CCXR25			20251503648	20109003620	8590019-xyyy
EHV 12.70/90	JN301207052CXR25			D226 (2)	CE159A	8590020-xyyy
	JN30100705CCXR25			20251503648	20109003620	8590021-xyyy
EHV 20.70/90	JN302007052CXR25			D226 (2)	CE159A	8590022-xyyy
	JN30100705CCXR25			20251503648	20109003620	8590023-xyyy
EHV 24,5.70/90	JN302407052CXR25			D226 (2)	CE159A	8590024-xyyy
	JN30100705CCXR25			20251503648	20109003620	8590025-xyyy
EHV 32.70/90	JN303207052CXR25			D226 (2)	CE159A	8590026-xyyy
	JN30100705CCXR25			20251503648	20109003620	8590027-xyyy
EHV 50.70/90	JN305007052CXR25			D226 (2)	CE159A	8590028-xyyy
	JN30500705CCXR25			20251503648	20109003620	8590029-xyyy

Type	Effective Gas vol. Litres	Design P bar	Weight kg	L (mm)	D (mm)	B (G2")	B (3/4" BSP)	C
EHV 10.70/90	11.5	70	27	394	220	103	-	66
						-	68	
EHV 12.70/90	14.5	70	32	493	220	103	-	66
						-	68	
EHV 20.70/90	21.2	70	41	703	220	103	-	66
						-	68	
EHV 24.5.70/90	25.5	70	50	851	220	103	-	66
						-	68	
EHV 32.70/90	38	70	65	1225	220	103	-	66
						-	68	
EHV 50.70/90	54.5	70	87	1740	220	103	-	66
						-	68	

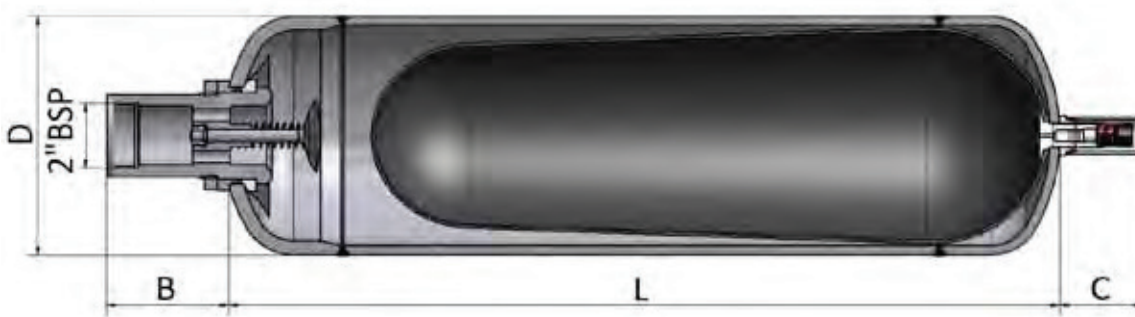
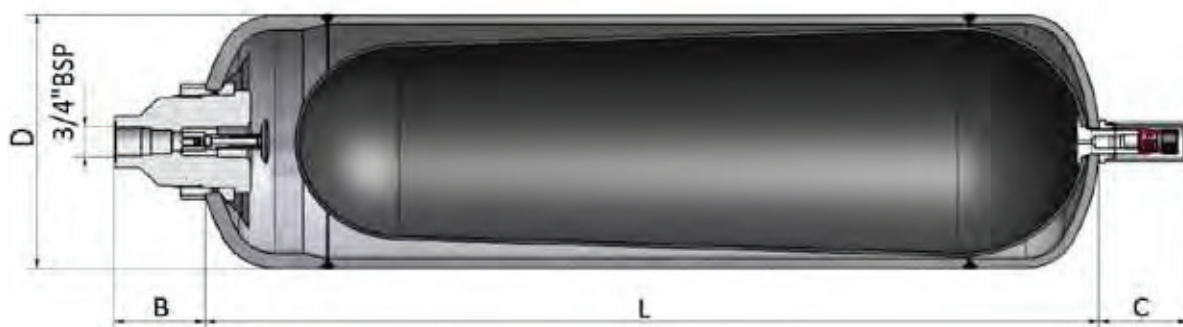

EHV Series 110 bar, 10 to 50 Litres

Standard version (**Stainless Steel** shell/bladder for mineral oils) temperature from - 20° up to 100°C

According to PED 97/23/EC, Fluid Group 1/2

Part numbers, Accessories, Dimensions

Type	Part number	Adaptor	Flanges	Clamps	Support Bracket	Complete Repair Kit
				Model (quantity)	Model	Part number
				Part number	Part number	
EHV 10.110/90	JL301011052CXR25	Various adaptors and flanges available		D226 (2)	CE159A	8590018-xyyy
	JL30101105CCXR25			20251503648	20109003620	8590019-xyyy
EHV 12.110/90	JL301211052CXR25			D226 (2)	CE159A	8590020-xyyy
	JL30121105CCXR25			20251503648	20109003620	8590021-xyyy
EHV 20.110/90	JL302011052CXR25			D226 (2)	CE159A	8590022-xyyy
	JL30201105CCXR25			20251503648	20109003620	8590023-xyyy
EHV 24,5.110/90	JL302411052CXR25			D226 (2)	CE159A	8590024-xyyy
	JL30241105CCXR25			20251503648	20109003620	8590025-xyyy
EHV 32.110/90	JL303211052CXR25			D226 (2)	CE159A	8590026-xyyy
	JL30321105CCXR25			20251503648	20109003620	8590027-xyyy
EHV 50.110/90	JL305011052CXR25			D226 (2)	CE159A	8590028-xyyy
	JL30501105CCXR25			20251503648	20109003620	8590029-xyyy

Type	Effective Gas vol. Litres	Design P bar	Weight kg	L (mm)	D (mm)	B		C
						(G2")	(3/4" BSP)	
EHV 10.110/90	10.3	110	48	405	226	103	-	66
						-	68	
EHV 12.110/90	13.1	110	59	504	226	103	-	66
						-	68	
EHV 20.110/90	19.7	110	82	714	226	103	-	66
						-	68	
EHV 24,5.110/90	23.9	110	90	862	226	103	-	66
						-	68	
EHV 32.110/90	36.1	110	123	1233	226	103	-	66
						-	68	
EHV 50.110/90	52.2	110	157	1752	226	103	-	66
						-	68	

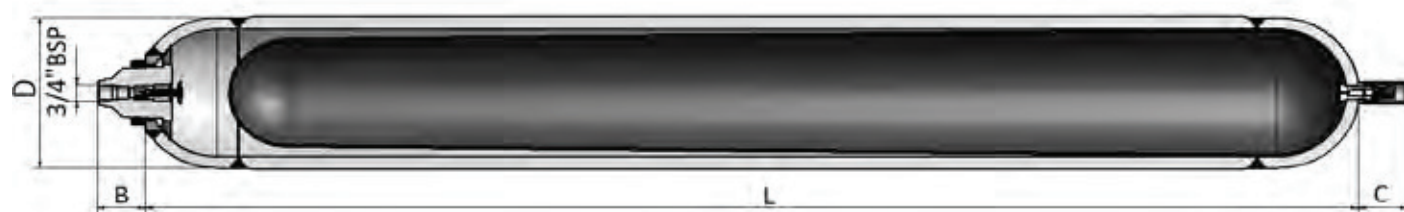
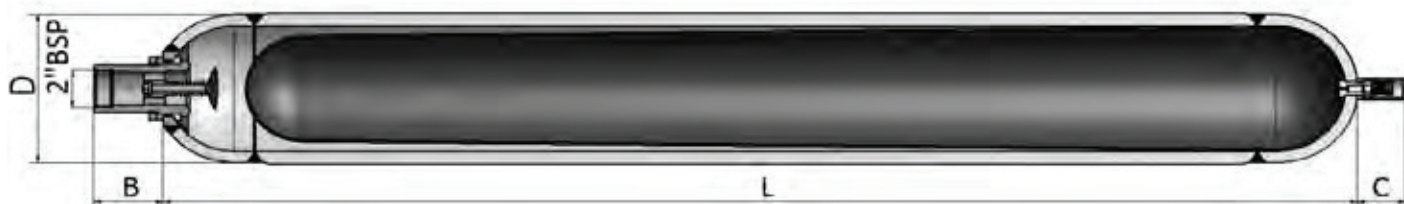

EHV Series 110 bar, 10 to 50 Litres

Standard version (**Stainless Steel** shell/bladder for mineral oils) temperature from - 20° up to 100°C

According to PED 97/23/EC, Fluid Group 1/2

Part numbers, Accessories, Dimensions

Type	Part number	Adaptor	Flanges	Clamps	Support Bracket	Complete Repair Kit
				Model (quantity)	Model	
				Part number	Part number	Part number
EHV 10.110/90	JS301011052CXR25	Various adaptors and flanges available		D226 (2)	CE159A	8590018-xyyy
	JS30101105CCXR25			20251503648	20109003620	8590019-xyyy
EHV 12.110/90	JS301211052CXR25			D226 (2)	CE159A	8590020-xyyy
	JS30121105CCXR25			20251503648	20109003620	8590021-xyyy
EHV 20.110/90	JS302011052CXR25			D226 (2)	CE159A	8590022-xyyy
	JS30201105CCXR25			20251503648	20109003620	8590023-xyyy
EHV 24,5.110/90	JS302411052CXR25			D226 (2)	CE159A	8590024-xyyy
	JS30241105CCXR25			20251503648	20109003620	8590025-xyyy
EHV 32.110/90	JS303211052CXR25			D226 (2)	CE159A	8590026-xyyy
	JS30321105CCXR25			20251503648	20109003620	8590027-xyyy
EHV 50.110/90	JS305011052CXR25			D226 (2)	CE159A	8590028-xyyy
	JS30501105CCXR25			20251503648	20109003620	8590029-xyyy

Type	Effective Gas vol. Litres	Design P bar	Weight kg	L (mm)	D (mm)	B (G2")	B (3/4" BSP)	C
EHV 10.110/90	10.3	110	46	400	226	103	68	66
EHV 12.110/90	13.1	110	58	498	226	103	68	66
EHV 20.110/90	19.7	110	70	708	226	103	68	66
EHV 24,5.110/90	23.9	110	80	856	226	103	68	66
EHV 32.110/90	36.1	110	105	1227	226	103	68	66
EHV 50.110/90	52.2	110	138	1745	226	103	68	66

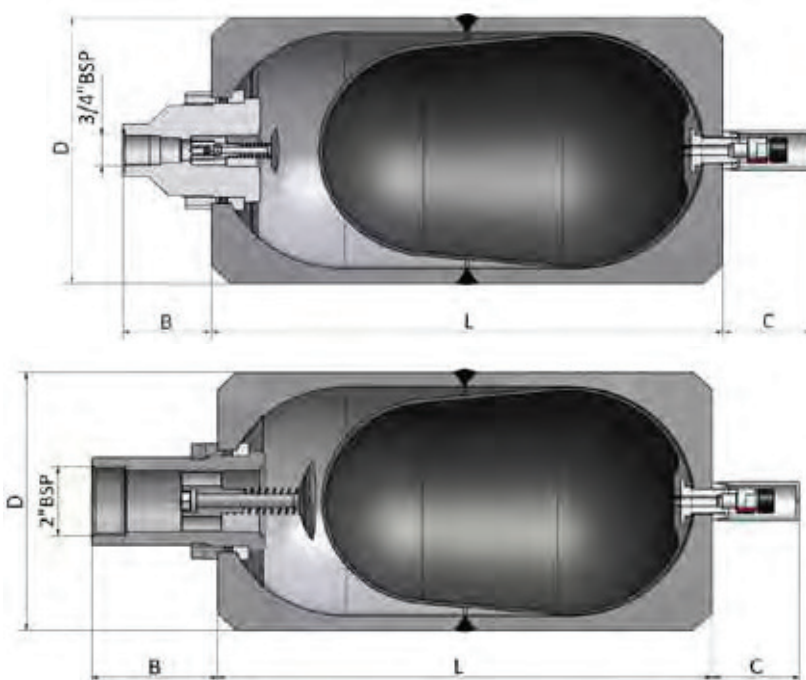

EHV Series 120 bar, 1 to 5 Litres

Stainless Version (**Stainless Steel** shell/NBR mix) for mineral oils temperatures from -40° up to 80°C.
 According to PED 97/23/EC, EN 14359 Fluid Group 1/2
Part numbers, Accessories, Dimensions

Type Part number	Pre-charge			Adaptor	Clamps	Support Bracket	Complete Repair Kit
	1 - 109 bar	110 - 209 bar	210 - 300 bar	Threaded Part number	Model Part number	Model Part number	Model Part number
EHV 1-120/00* 10953701925	751001	751030	751045	G 3/4" cyl 04555201723	Consult Page 116	CE 89 20151901220	KIT EHV 1-120/00 19039501725
EHV 2.5-120/90 10953401925	751002	751031	751046	G 3/4" cyl 04555201723		CE 89 20151901220	KIT EHV 2.5-120/90 19029801725
EHV 5-120/90 10953501925	751003	751032	751047	G 3/4" cyl 04555201723		CE 89 20151901220	KIT EHV 5-120/90 19030001725

* Conforming to the EC regulation 3.3

Model of valve stem
 7/8"14 UNF

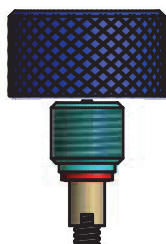

Type	Effective Gas vol. Litres	Max. Working pressure (PS) bar	Max Flow Rate lt/min	Max Weight kg	Gas connection	Dimensions in mm							
						A max height	B	C	øD max	ød	øE	øG connection	F on flats
EHV 1-120/00*	1	120	450	6	7/8" 14 UNF	345	67	66	116	22.5	68	G 1¼"	50
EHV 2.5-120/90	2.4	120	450	11	7/8" 14 UNF	542	67	66	116	22.5	68	G 1¼"	50
EHV 5-120/90	5	120	450	17	7/8" 14 UNF	891	67	66	116	22.5	68	G 1¼"	50

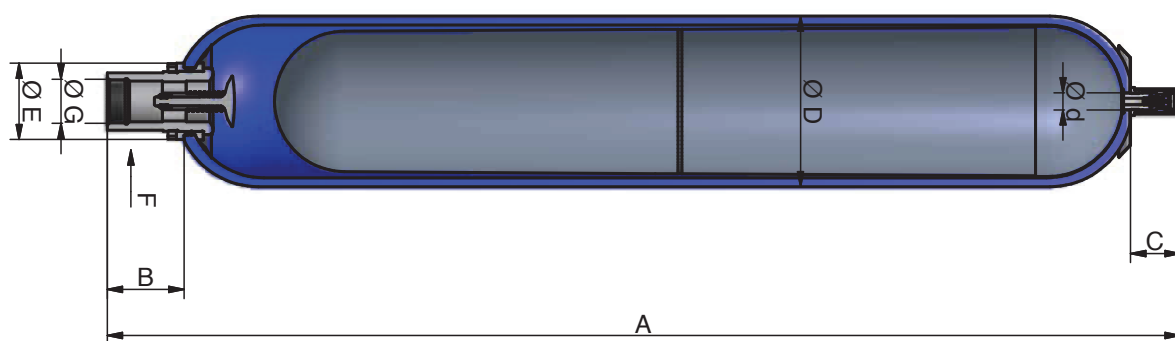

Adaptors EHV Carbon Steel

Accumulator model	Connection of accumulator ø F gas cyl.	Connection of fitting ø I gas cyl.	Part Number
EHV 0.5 & 1 & 1.6 Litres 350 Bar	3/4"	3/8"	04556400223
		Blind	04556100223
			04502000223
			04558200223
EHV 2.5 to 10 Litres 350 Bar	1 1/4"	1/2"	04555100233
			04592600223
		3/4"	04555200223
			04592700223
		Blind	04502200223
			04558300223
EHV 0.2 Litres 350 Bar	1/2"	1/4"	04556500223
		Blind	04501800223
EHV 1 to 5 Litres 690 Bar	1"	1/2"	04579500223
		Blind	04579600223
EHV 10 to 50 Litres 330/480 Bar	2"	1/2"	04585400223
			04578802523
		3/4"	04592400223
			04578902523
		1"	04523700223
			04579002523
		1 1/4"	04592500223
			04579102523
		Blind	04502400223
			04579202523
EHV 10 to 50 Litres 690 Bar	2"	1"	On Request
		Blind	On Request

Flanges EHV Carbon Steel

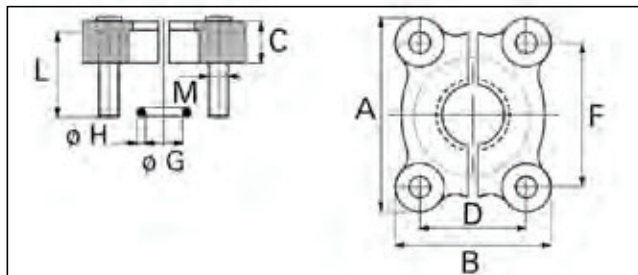

Accumulator model	Type	Part Number
EHVF 2,5 to 10 Litres	BR 400-25	35132600123
EHVF 10 to 57 Litres	BR 400-38	35124000123

Shape	J/Flats	K	O-Ring & Back-up ring
A	32	8	O-Ring 21,3 x 2,4
B			O-Ring 16,9 x 2,7
A			O-Ring 21,3 x 2,4
B			O-Ring 16,9 x 2,7
A	50	10	O-Ring 36.2 x 3
B			O-Ring 30 x 3
A			O-Ring 36.2 x 3
B		O-Ring 30 x 3	
A		40	O-Ring 36.2 x 3
B			O-Ring 30 x 3
A			O-Ring 36.2 x 3
B	O-Ring 30 x 3		
A	27	8	O-Ring 18 x 2
B	41	10	O-Ring 21.3 x 3.6 / BUR 22 x 28 x 0.69 * 2
A	65	13	O-Ring 54 x 3
B		15	O-Ring 43,82 x 5,33 / BUR 45 x 54 x 0,85 * 2
A		13	O-Ring 54 x 3
B		15	O-Ring 43,82 x 5,33 / BUR 45 x 54 x 0,85 * 2
A		13	O-Ring 54 x 3
B		15	O-Ring 43,82 x 5,33 / BUR 45 x 54 x 0,85 * 2
A			O-Ring 54 x 3
B		13	O-Ring 43,82 x 5,33 / BUR 45 x 54 x 0,85 * 2
A			O-Ring 54 x 3
B		15	O-Ring 43,82 x 5,33 / BUR 45 x 54 x 0,85 * 2

Adaptors EHV

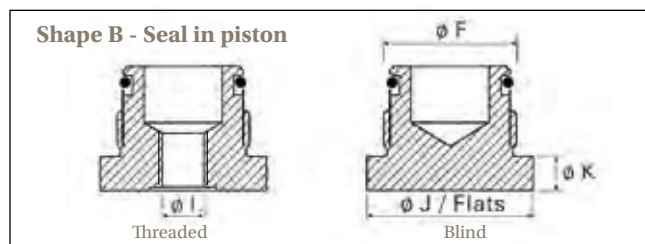
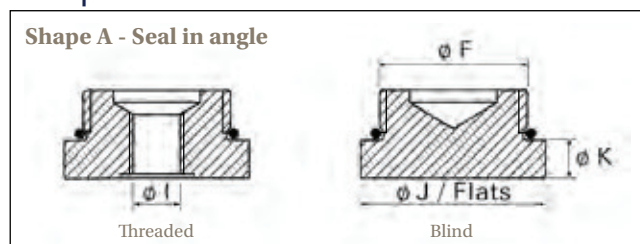

A	B	C	D	F	G	H	L	M
81	70	24	27,75	57,15	32,92	3,53	40	M12
113	95	30	36,5	79,4	47,22	3,53	50	M16

Regulations

Regulations for EBV and EHV Bladder Accumulators Carbon Steel

Regulations available from Parker Olaer.

Designation	EUROPE				USA		CHINA		CANADA		AUSTRALIA	
	/90	/90	/90	Max. Working Pressure bar	/15 /48	Max. Working Pressure Psi (bar)	/85	Max. Working Pressure bar	/92	Max. Working Pressure Psi (bar)	/83 /91	Max. Working Pressure bar
Approvals	CE Fluid Group 2 EN 14359	CE Fluid Group 1 EN 14359	ATEX EX		ASME VIII div 1		SELO		CRN		AS1210	
Models												
EBV 0.5 L	X	X	X	40								
EBV 0.5 L	X	X	X	50								
EBV 1 to 5 L	X	X	X	40			X	40				
EBV 1 to 5 L	X	X	X	80			X	80				
EBV 10 to 50 L	X	X		16								
EBV 10 to 50 L	X	X	X	40	On Request	580 (40)						
EBV 100 to 200 L	X	X		16								
EBV 100 to 200 L	X	X	X	20			X	20				
EBV 100 to 200 L	X	X	X	40			X	40				
EBV 100 to 200 L	X	X		50								
EBV 100 to 575 L	X	X	X	8								
EBV 100 to 575 L	X	X		10								
EBV 100 to 575 L	X	X		15								
EBV 100 to 575 L	X	X	X	16								
EBV 100 to 575 L	X	X	X	20								
EBV 100 to 575 L	X	X	X	40								
EHV 0,5L	X	X	X	350			X	350				
EHV 1 to 5 L	X	X	X	300			X	300				
EHV 1 to 5 L	X	X	X	350			X	350			On Request	350
EHV 1 to 5 L	X	X	X	690			X	690				
EHV 2.5L to 5 L	X	X	X	120			X	120				
EHV 4 - 6 - 10 L	X	X	X	210			X	210				
EHV 4 - 6 - 10 L	X	X	X	350	On Request	4000 (276 Bar)	X	350			On Request	320
EHV 4 to 60 L					On Request	5000 (345 Bar)						
EHV 4 to 60 L					On Request	6000 (413 Bar)						
EHV 10 to 42 L					On Request	3000 (207 Bar)			X	3000 (207 Bar)		
EHV 10 to 42 L					On Request	3600 (248 Bar)			X	3600 (248 Bar)		
EHV 10 to 42 L					On Request	4000 (276 Bar)			X	4000 (276 Bar)		
EHV 10 to 50 L	X	X	X	690			X	690				
EHV 10 to 57 L					On Request	3600 (248 Bar)					On Request	248
EHV 10 to 57 L					On Request	4000 (276 Bar)					On Request	276
EHV 10 to 57 L	X	X		480			X	480			On Request	400
EHV 10 to 60 L	X	X	X	300	On Request	3000 (207 Bar)	X	300				
EHV 10 to 60 L	X	X	X	330	On Request	3600 (248 Bar)	X	330				
EHV 10 to 60 L	X	X	X	480			X	480				
EHV 50 to 57 L					On Request	3000 (207 Bar)			X	3000 (207 Bar)		
EHV 50 to 57 L					On Request	3600 (248 Bar)			X	3600 (248 Bar)		
EHV 50 to 57 L					On Request	4000 (276 Bar)			X	4000 (276 Bar)		
EHV 100 to 200 L	X	X		300			X	300				
EHVF 2.5 to 10 L	X	X		350			X	350				
EHVF 10 to 50 L	X	X		250			X	250				
EHVF 10 to 50 L	X	X		330			X	330				

Multi Approvals are possible

Codification	Regulation
90 EX	CE+ATEX
94	CE+ASME
88	CE+SELO
86	CE+ASME+SELO



Stainless Steel

Other regulations available on request (ARH, DOSH, MOM, RI.N.A., RT)

BRASIL		RUSSIA		MARINE - OFFSHORE			Designation		
/AA /AE /AM	Max. Working Pressure bar	/71 /AU	Max. Working Pressure bar	/24	/11	/41			
NR13		GOST R		DNV Mobile ships	Bureau Veritas Marine	ABS American Bureau of Shipping	Max. Working Pressure bar	Approvals* Models*	
X	40	On Request	40				EBV 0.5 L		
X	50		50				EBV 0.5 L		
X	40		40				EBV 1 to 5 L		
X	80		80				EBV 1 to 5 L		
X	16		16				EBV 10 to 50 L		
X	40		40				EBV 10 to 50 L		
X	16		16				EBV 100 to 200 L		
X	20		20				EBV 100 to 200 L		
X	40		40				EBV 100 to 200 L		
X	50		50				EBV 100 to 200 L		
X	8		8				EBV 100 to 575 L		
X	10		10				EBV 100 to 575 L		
X	15		15				EBV 100 to 575 L		
X	16		16				EBV 100 to 575 L		
X	20		20				EBV 100 to 575 L		
X	40	40				EBV 100 to 575 L			
X	350	On Request	350	X		X	350	EHV 0,5L	
			300					350	EHV 1 to 5 L
X	350		350	X	X	X		350	EHV 1 to 5 L
X	690		690						EHV 1 to 5 L
X	120		120						EHV 2.5L to 5 L
X	210		210						EHV 4 - 6 - 10 L
X	350		350	X	X	X		350	EHV 4 - 6 - 10 L
X	345		345						EHV 4 to 60 L
X	413		413						EHV 4 to 60 L
X	207		207						EHV 10 to 42 L
X	248		248						EHV 10 to 42 L
X	276		276						EHV 10 to 42 L
X	690		690						EHV 10 to 50 L
X	248		248						EHV 10 to 57 L
X	276		276						EHV 10 to 57 L
X	480		480						EHV 10 to 57 L
X	300		300						EHV 10 to 60 L
X	330		330	X	X	X		330	EHV 10 to 60 L
X	480		480						EHV 10 to 60 L
X	207		207						EHV 50 to 57L
X	248	248						EHV 50 to 57 L	
X	276	276						EHV 50 to 57 L	
X	300	300						EHV 100 to 200 L	
X	350	On Request	350					EHVF 2.5 to 10 L	
X	330		330						EHVF 10 to 50 L
X	330		330						EHVF 10 to 50 L

This table is giving an indication of approval availability for the range of products. Availability is to be confirmed for each approval, in particular the pressure rating and the allowable working temperatures.

Corrosion protection Bladder Accumulators

Protections available from Parker Olaer. Additionnal prices over standard for bladder accumulators.

Calculation Example

	Base Price	Add for change of protection	Total cost for this special
Complete Accumulator: 4 liter complete accumulator with protection Rilsan 85	x (from page 34)	x	x

	EPOXY 80 microns Internal	NICKEL PLATING 50 microns Internal/External	RILSAN® 200-300 microns Internal/External		Marine Painting C3 170 microns External
Valve Stem, Fluid port, and Protection Cap	Stainless Steel	Stainless Steel	Stainless Steel	Standard Steel	Standard Steel
Codes	20	50	84	85	xx
Volume	All prices below are in addition (on top of) the standard construction carbon steel 11 on top of the complete base, accumulator cost when ordered complete as a bladder accumulator with special characteristics.				
0,2	x	x	x	x	x
0,5	x	x	x	x	x
1	x	x	x	x	x
1,6	x	x	x	x	x
2,5	x	x	x	x	x
4	x	x	x	x	x
5	x	x	x	x	x
6	x	x	x	x	x
10 (DIA 170)	x	x	x	x	x
10 (DIA 226)	x	x	x	x	x
12	x	x	x	x	x
20	x	x	x	x	x
24,5	x	x	x	x	x
32	x	x	x	x	x
42	x	x	x	x	x
50	x	x	x	x	x
57	x	x	x	x	x
100	x	x	x	x	x
200	x	x	x	x	x

This is showing the options, prices are available on request

Depending on your application, fluid and the environment in which you install your systems/equipment, Parker can offer a variety of internal and external shell coatings for your bladder accumulator. Please contact our technical support or your local accumulator expert if you are uncertain what you may require or for more details on the various coatings.

For the range concerning 100 to 575 L pages 14 to 18, 22 and 23: Consult Division.

Bladder Materials and Types

Bladder mixes available from Parker Olaer. Additional prices over standard for bladder accumulators series EBV/EHV.

Calculation Example EHV

	Base Price	add for change of mix	Total cost for this special
Complete Accumulator: 4 liter complete accumulator with mix 80 (viton) bladder	x (from page 34)	x	x
Spare Bladder Kit: 4 liter spare bladder mix 80 (viton) bladder	x (from page 34)	x	x

Mix Number	Standard Bladder	For other bladder mixes as spare parts, start with the cost for NBR, Mix 25. For complete accumulators with special bladders, start with the base cost of a standard accumulator and then add the additional cost listed below.								
	Mix 25	Mix 02	Mix 10	Mix 20	Mix 30	Mix 35	Mix 37	Mix 40	Mix 47	Mix 80
Mix Name	Standard NBR (Nitrile)	Hydrin C	Low Temp Nitrile	Heavy Duty Nitrile	Low Nitrile Permeability	High Temp Nitrile	Extreme Low Temp Nitrile	Butyl	EPDM	Viton
Max Temp °C	100	115	70	110	115	130	110	120	120	140
Min Temp °C	- 20	- 32	- 28	- 6	- 5	0	- 59	- 15	- 40	-20
Typical Fluid	Mineral Oil	Mineral Oil	Mineral Oil	Mineral Oil	Mineral Oil + Special fuels (not unleaded gasoline)	Mineral Oil	Consult Parker Olaer regarding fluid and application	Water based fluids	Phosphate esters	Aggressive fluids
Volume	Mix 25 bladder kit cost(spares) or on top of the complete base, Mix 25 accumulator cost when ordered complete as a bladder accumulator with special bladder mix.									
0,2	Standard, no extra costs.	x	x	-	x	x	x	x	x	x
0,5		x	x	x	x	x	x	x	x	x
1		x	x	x	x	x	x	x	x	x
1,6		x	x	x	x	x	x	x	x	x
2,5		x	x	x	x	x	x	x	x	x
4		x	x	x	x	x	x	x	x	x
5		x	x	x	x	x	x	x	x	x
6		x	x	x	x	x	x	x	x	x
10 (DIA 170)		x	x	x	x	x	x	x	x	x
10 (DIA 226)		x	x	x	x	x	x	x	x	x
12		x	x	x	x	x	x	x	x	x
20		x	x	x	x	x	x	x	x	x
24,5		x	x	x	x	x	x	x	x	x
32		x	x	x	x	x	x	x	x	x
42		x	x	x	x	x	x	x	x	x
50		x	x	x	x	x	x	x	x	x
57		x	x	x	x	x	x	x	x	x
100*		x	x	-	x	x	x	x	x	x
200*	x	x	-	x	x	x	x	x	x	

* Accumulators 100 & 200 Litres Standard Nitrile Mix 20

For the range concerning 100 to 575 L pages 14 to 18, 22 and 23: Consult Division.

General Information Piston Accumulators

Operation of the Parker Olaer gas loaded piston accumulator is based on the considerable difference in compressibility between a gas and a liquid, enabling a large quantity of energy to be stored in an extremely compact form. This enables a liquid under pressure to be accumulated, stored and recovered at any time.

When fluid under pressure enters the fluid side of the accumulator, the piston is pushed towards the gas side and the Nitrogen gas is compressed. Parker Olaer piston accumulators can be supplied with a large variety of seals suitable for high and low pressures and temperatures as well as special fluids. This is part of the flexibility of the Piston Accumulator; materials in all components can be chosen to best fit the application.

Technical Characteristics

The accumulator comprises of a pressure vessel, a piston and its seals.

- Shell material options include standard carbon steel, alloyed steel, stainless steel, aluminium, titanium and composites. The main requirement is that the material is suitable and approved for use in pressure vessels.
- For most standard industrial and mobile systems the piston is made from light weight aluminium. To improve resistance to certain fluids, this is sometimes anodized. In special

applications, the pistons are made from the same material as the pressure vessel. In some special applications, Parker Olaer piston accumulators can also be supplied with pistons made from composite materials.

- The sealing systems in the piston accumulator are the key working components, and also where we have focused resources selecting the correct type and material. Depending on the customer application, our engineers will choose the most optimum solution.

Taking into account the different needs of various applications, Parker proposes different corrosion protections external and/or internal: Bare metal, electroless nickel plating, standard primer, epoxy paint etc. This extensive range enables us to offer accumulators operating from - 45 to +200°C with pressures of up to 3000 Bar and capacities in excess of 1000 litres.

As one of few global companies in the piston accumulator market, Parker Olaer has participated in the development of the EN 14359:2006 standard, which specifies the material, design, manufacturing, tests, safety devices and documentation (including the instruction manual), for pressure accumulators and gas bottles for hydraulic applications.

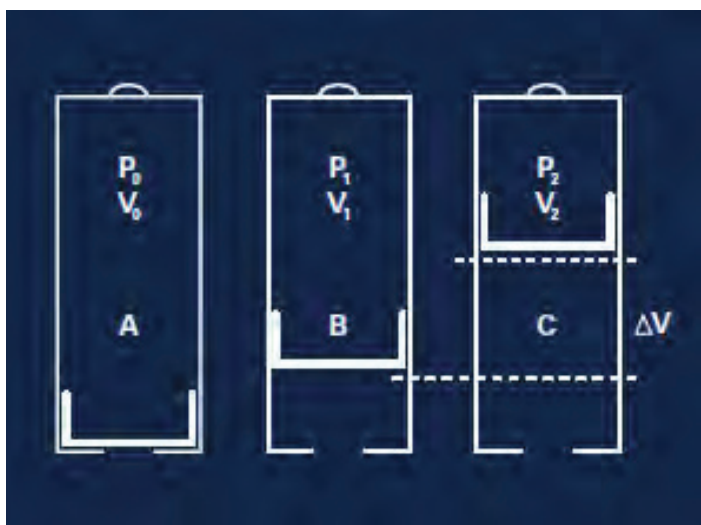

V0 = Capacity in nitrogen of the accumulator
V1 = Gas volume at the minimum hydraulic pressure
V2 = Gas volume at the maximum hydraulic pressure
 ΔV = Returned and/or stored volume between P1 and P2
P0 = Initial preload of the accumulator
P1 = Gas pressure at the minimum hydraulic pressure
P2 = Gas pressure at the maximum hydraulic pressure

EHP Series: How to order a Piston Accumulator

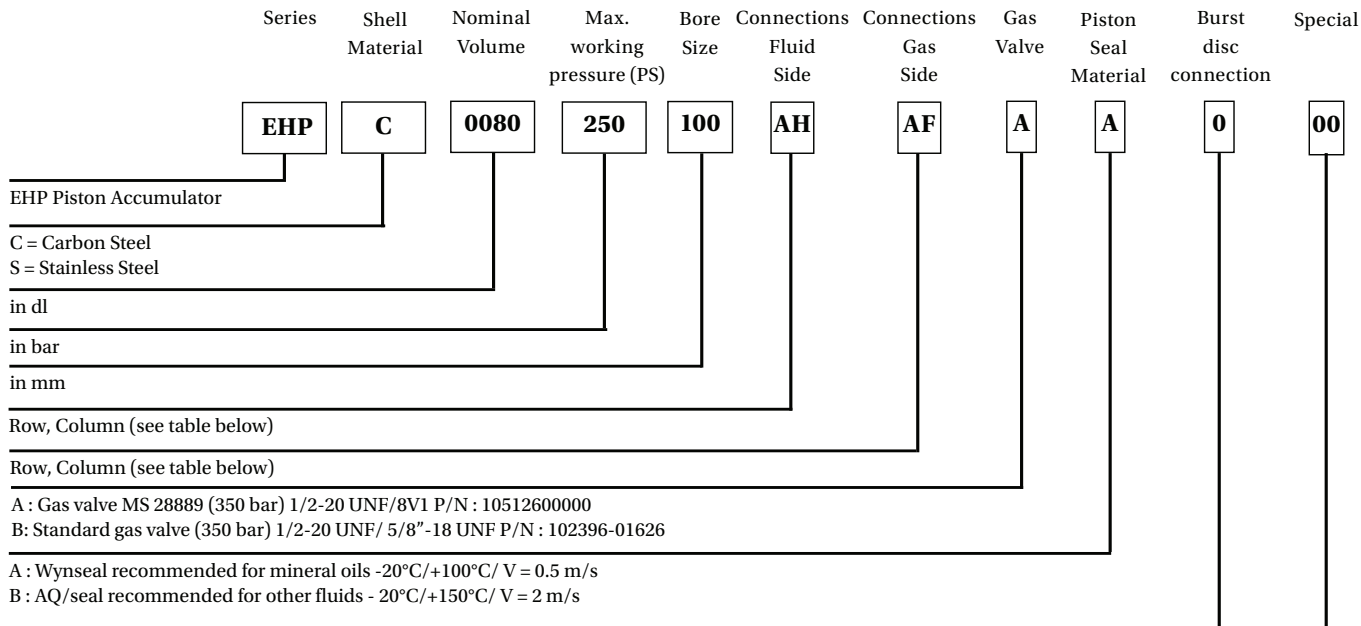

Code	Burst Disc	Size
0	Without burst disc, no connection	
A	275 Bar/80°C	G 1/4"
B	385 Bar/80°C	G 1/4"
C	230 Bar/80°C	G 1/4"
D	250 Bar/80°C	G 1/4"
E	300 Bar/80°C	G 1/4"
F	420 Bar/80°C	G 1/4"
K	230 Bar/80°C	
L	275 Bar/80°C	
M	385 Bar/80°C	
N	without burst disc. Plugged connection	NPT 1/4"
P	without burst disc. Plugged connection	G 1/4"
R	300 Bar/80°C	
X	Special	

00 = Standard with precharge and paint defined on the order
0Z = Special : to be defining on the order

Specification	A	B	C	D	E	F	G	H	I	K	L	M	N
Thread to ISO228-1 (G)	G1/8"-28	G1/4"-19	G3/8"-19	G1/2"-14	G5/8"-14	G3/4"-14	G7/8"-14	G1"-11	G 1 1/4"-11	G1 1/2"-11	G2"-11	G2 1/2"-11	G3"-11
SAE Flange (ISO 6162)	1/2" 210 Bar	3/4" 210 Bar	1" 210 Bar	1 1/4" 210 Bar	1 1/2" 210 Bar	2" 210 Bar	2 1/2" ca 175 Bar	3" ca 140 Bar					
SAE Flange	1/2" 3000 psi	3/4" 3000 psi	1" 3000 psi	1 1/4" 3000 psi	1 1/2" 3000 psi	2" 3000 psi	2 1/2" 3000 psi	3" 3000 psi					
SAE Port (UN)	#5 1/2"-20	#6 9/16"-18	#8 3/4"-16	#10 7/8"-14	#12 1 1/16"-12	#16 1 5/16"-12	#20 1 5/8"-12	#24 1 7/8"-12	#32 2 1/2"-12				
Metric (ISO 6149-1)	M10 x 1	M12 x 1,5	M14 x 1,5	M18 x 1,5	M22 x 1,5	M27 x 2	M33 x 2	M42 x 2	M48 x 2				

Piston Accumulators**EHP Series 207 bar, 60 to 400 Litres, Ø 360**

Standard version (**Stainless Steel** shell/seals for mineral oils) temperature from - 15° up to 100°C. Maximum Piston Speed 2 m/s. Suitable for Mineral based hydraulic fluids, Vegetable oils, Water Glycols. For other fluids please contact Parker Olaer. According to PED 97/23/EC, Fluid Group 1/2.

Part numbers, Dimensions

Type	Part number
EHP(G) S 0600-207-360	815EHPGS0602036
EHP(G) S 0700-207-360	815EHPGS0702036
EHP(G) S 0800-207-360	815EHPGS0802036
EHP(G) S 0900-207-360	815EHPGS0902036
EHP(G) S 1000-207-360	815EHPGS1002036
EHP(G) S 1500-207-360	815EHPGS1502036
EHP(G) S 2000-207-360	815EHPGS2002036
EHP(G) S 2500-207-360	815EHPGS2502036
EHP(G) S 3000-207-360	815EHPGS3002036
EHP(G) S 3500-207-360	815EHPGS3502036
EHP(G) S 4000-207-360	815EHPGS4002036

Piston Accumulators

Type	Effective Gas vol. Litres	Design P bar	Weight kg	L mm	D mm	d mm	Std Fluid opening	A mm	Seal Kit
EHP(G) S 0600-207-360	60	207	446	1106	408	360	G2"	45	8220000000016
EHP(G) S 0700-207-360	70	207	467	1204	408	360	G2"	45	8220000000016
EHP(G) S 0800-207-360	80	207	488	1303	408	360	G2"	45	8220000000016
EHP(G) S 0900-207-360	90	207	509	1401	408	360	G2"	45	8220000000016
EHP(G) S 1000-207-360	100	207	530	1500	408	360	G2"	45	8220000000016
EHP(G) S 1500-207-360	150	207	635	1990	408	360	G2"	45	8220000000016
EHP(G) S 2000-207-360	200	207	740	2481	408	360	G2"	45	8220000000016
EHP(G) S 2500-207-360	250	207	845	2973	408	360	G2"	45	8220000000016
EHP(G) S 3000-207-360	300	207	950	3464	408	360	G2"	45	8220000000016
EHP(G) S 3500-207-360	350	207	1055	3955	408	360	G2"	45	8220000000016
EHP(G) S 4000-207-360	400	207	1160	4426	408	360	G2"	45	8220000000016

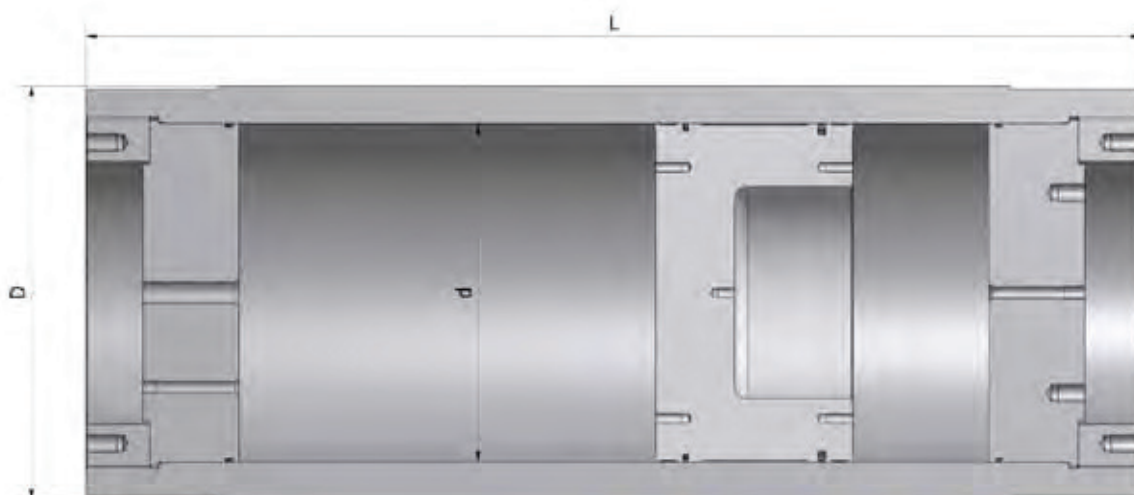

EHP Serie 220 bar, 150 to 650 Litres, Ø 540

Standard version (Carbon Steel shell/seals for mineral oils) temperature from - 15° up to 100°C. Maximum Piston Speed 2 m/s. Suitable for Mineral based hydraulic fluids, Vegetable oils, Water Glycols. For other fluids please contact Parker Olaer. According to PED 97/23/EC, Fluid Group 1/2

Part numbers, Dimensions

Type	Part number
EHP(G) C 1500-220-540	815EHPGC15002254
EHP(G) C 2000-220-540	815EHPGC20002254
EHP(G) C 2500-220-540	815EHPGC25002254
EHP(G) C 3000-220-540	815EHPGC30002254
EHP(G) C 3200-220-540	815EHPGC32002254
EHP(G) C 3400-220-540	815EHPGC34002254
EHP(G) C 3600-220-540	815EHPGC36002254
EHP(G) C 3800-220-540	815EHPGC38002254
EHP(G) C 4000-220-540	815EHPGC40002254
EHP(G) C 4500-220-540	815EHPGC45002254
EHP(G) C 5000-220-540	815EHPGC50002254
EHP(G) C 5500-220-540	815EHPGC55002254
EHP(G) C 6000-220-540	815EHPGC60002254
EHP(G) C 6500-220-540	815EHPGC65002254

Type	Effective Gas vol. Litres	Design P bar	Weight kg	L mm	D mm	d mm	Max Fluid opening	Seal Kit
EHP(G) C 1500-220-540	150	220	2147	1415	630	540	G3"	8220000000018
EHP(G) C 2000-220-540	200	220	2280	1633	630	540	G3"	8220000000018
EHP(G) C 2500-220-540	250	220	2413	1851	630	540	G3"	8220000000018
EHP(G) C 3000-220-540	300	220	2546	2068	630	540	G3"	8220000000018
EHP(G) C 3200-220-540	320	220	2625	2156	630	540	G3"	8220000000018
EHP(G) C 3400-220-540	340	220	2702	2243	630	540	G3"	8220000000018
EHP(G) C 3600-220-540	360	220	2780	2331	630	540	G3"	8220000000018
EHP(G) C 3800-220-540	380	220	2857	2418	630	540	G3"	8220000000018
EHP(G) C 4000-220-540	400	220	3004	2505	630	540	G3"	8220000000018
EHP(G) C 4500-220-540	450	220	3128	2723	630	540	G3"	8220000000018
EHP(G) C 5000-220-540	500	220	3322	2942	630	540	G3"	8220000000018
EHP(G) C 5500-220-540	550	220	3516	3160	630	540	G3"	8220000000018
EHP(G) C 6000-220-540	600	220	3711	3379	630	540	G3"	8220000000018
EHP(G) C 6500-220-540	650	220	3904	3597	630	540	G3"	8220000000018

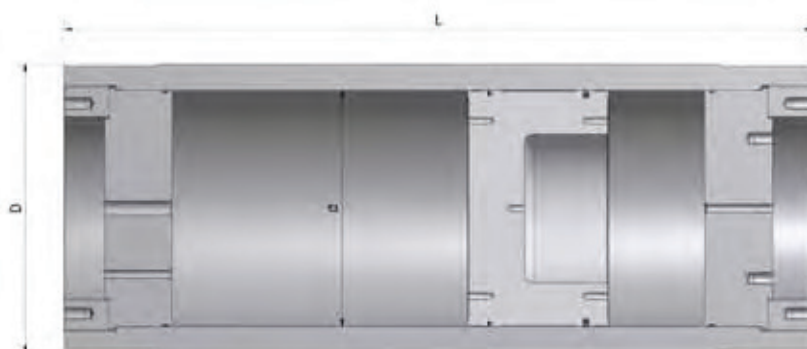

EHP Series 250 bar, 0.3 to 4 Litres, Ø 80

Standard version (Carbon steel/Wynseal) for mineral oils, According to PED 97/23/EC, EN14359-2006

Part numbers, Dimensions

Most common configurations

Type Part number	Pre-charge			Wynseal Piston Kit	Without burst disc. Plugged connection
	1 - 109 bar	110 - 209 bar	210 - 300 bar	Part number	Model Part number
EHP-C-0010-250-080-AF00AA000 (1) 9000-0701-AF00-AA000	751001	751030	751045	9782-080-003	-
EHP-C-0010-250-080-AF00AAP00 (1) 9000-0701-AF00-AAP00	751001	751030	751045	9782-080-003	Consult Division
EHP-C-0020-250-080-AB00AA000 (2) 9098-1001-AB00-AA000	751002	751031	751046	9782-080-003	-
EHP-C-0020-250-080-AF00AA000 (2) 9098-1001-AF00-AA000	751002	751031	751046	9782-080-003	-
EHP-C-0020-250-080-AF00AAP00 (2) 9098-1001-AF00-AAP00	751002	751031	751046	9782-080-003	Consult Division
EHP-C-0030-250-080-AF00AA000 (2) 9098-1301-AF00-AA000	751002	751031	751046	9782-080-003	-
EHP-C-0040-250-080-AF00AA000 (2) 9098-1601-AF00-AA000	751012	751020	751035	9782-080-003	-

CE Marked complies with group fluid 2 according to the PED 97/23/EC

(1) according to the PED, article 3.3

(2) Category III

Type	Effective Gas vol. Litres	Max. Working pressure (PS) bar	Dia Bore	Max Flow Rate lt/min	Allowable Temperature °C	Weight kg	A max height	External øD max	Oil port connection	V m/s
EHP-C-0010-250-080-AF00AA000 (1)	1	250	80	151	-20/+80	14.4	785	92	G 3/4"	0,5
EHP-C-0010-250-080-AF00AAP00 (1)	1	250	80	151	-20/+80	14.4	785	92	G 3/4"	0,5
EHP-C-0020-250-080-AB00AA000	2	250	80	151	-20/+80	11.9	586	92	G 1/4"	0,5
EHP-C-0020-250-080-AF00AA000	2	250	80	151	-20/+80	11.9	586	92	G 3/4"	0,5
EHP-C-0020-250-080-AF00AAP00	2	250	80	151	-20/+80	11.9	586	92	G 3/4"	0,5
EHP-C-0030-250-080-AF00AA000	3	250	80	151	-20/+80	14.4	785	92	G 3/4"	0,5
EHP-C-0040-250-080-AF00AA000	4	250	80	151	-20/+80	16.9	984	92	G 3/4"	0,5

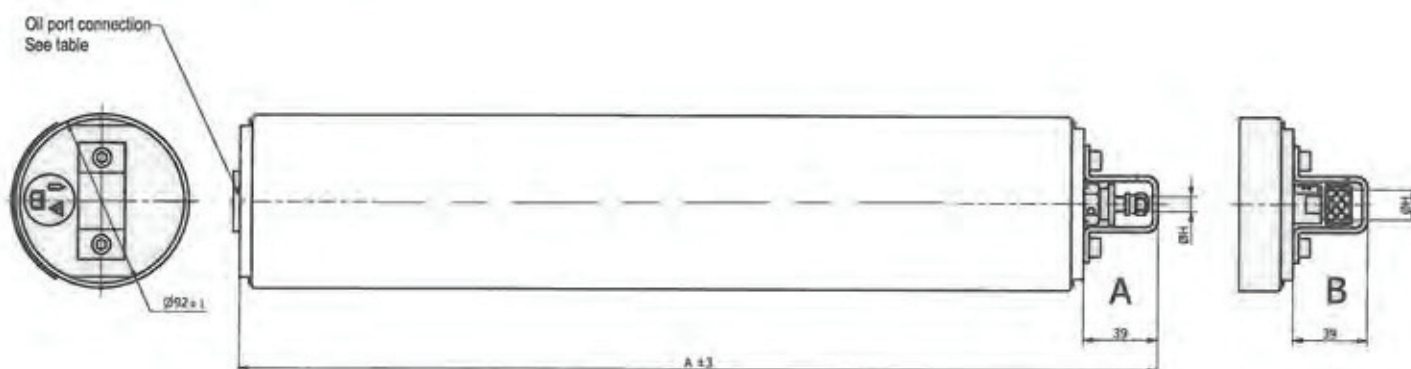

Above dimensions are in mm and are subject to manufacturing tolerances.

EHP Series 250 bar, 2 to 12 Litres, Ø 100

Standard version (Carbon steel/Wynseal) for mineral oils, According to PED 97/23/EC, EN14359-2006

Part numbers, Dimensions

Most common configurations

Type Part number	Pre-charge			Wynseal Piston Kit	Without burst disc. Plugged connection
	1 - 109 bar	110 - 209 bar	210 - 300 bar	Part number	Model Part number
EHP-C-0020-250-100-AD00AA000 (1) 9098-1002-AD00-AA000	751002	751031	751046	9782-100-001	-
EHP-C-0020-250-100-AF00AA000 (1) 9098-1002-AF00-AA000	751002	751031	751046	9782-100-001	-
EHP-C-0040-250-100-AD00AA000 (1) 9098-1602-AD00-AA000	751012	751020	751035	9782-100-001	-
EHP-C-0040-250-100-AF00AA000 (1) 9098-1602-AF00-AA000	751012	751020	751035	9782-100-001	-
EHP-C-0040-250-100-DF00AA000 (1) 9098-1602-DF00-AA000	751015	751020	751035	9782-100-001	-
EHP-C-0060-250-100-AF00AA00 (2) 9098-1902-AF00-AA000	751015	751021	751036	9782-100-001	-
EHP-C-0060-250-100-AH00AA000 (2) 9098-1902-AH00-AA000	751015	751021	751036	9782-100-001	-
EHP-C-0080-250-100-AF00AA000 (2) 9098-2002-AF00-AA000	751004	751022	751037	9782-100-001	-
EHP-C-0080-250-100-AH00AAP00 (2) 9098-2002-AH00-AAP00	751004	751022	751037	9782-100-001	Consult Division
EHP-C-0100-250-100-AH00AA000 (2) 9098-2102-AH00-AA000	751004	751022	751037	9782-100-001	-
EHP-C-0100-250-100-AH00AAP00 (2) 9098-2102-AH00-AAP00	751004	751022	751037	9782-100-001	Consult Division

CE Marked complies with group fluid 2 according to the PED 97/23/EC

(1) Category II

(2) Category III

Type	Effective Gas vol. Litres	Max. Working pressure (PS) bar	Dia Bore	Max Flow Rate lt/min	Allowable Temperature °C	Weight kg	A max height	External øD max	Oil port connection	V m/s
EHP-C-0020-250-100-AD00AA000 (1)	2	250	100	236	-20/+80	15.2	441	115	G 1/2"	0,5
EHP-C-0020-250-100-AF00AA000 (1)	2	250	100	236	-20/+80	15.2	441	115	G 3/4"	0,5
EHP-C-0040-250-100-AD00AA000 (1)	4	250	100	236	-20/+80	20.2	696	115	G 1/2"	0,5
EHP-C-0040-250-100-AF00AA000 (1)	4	250	100	236	-20/+80	20.2	696	115	G 3/4"	0,5
EHP-C-0040-250-100-DF00AA000 (1)	4	250	100	236	-20/+80	20.2	696	115	#16 1 5/16"	0,5
EHP-C-0060-250-100-AF00AA00 (2)	6	250	100	236	-20/+80	25.3	951	115	G 3/4"	0,5
EHP-C-0060-250-100-AH00AA000 (2)	6	250	100	236	-20/+80	25.3	951	115	G 1"	0,5
EHP-C-0800-250-100-AF00AA000 (2)	8	250	100	236	-20/+80	30.3	1205	115	G 3/4"	0,5
EHP-C-0800-250-100-AH00AAP00 (2)	8	250	100	236	-20/+80	30.3	1205	115	G 1"	0,5
EHP-C-0100-250-100-AH00AA000 (2)	10	250	100	236	-20/+80	35.3	1460	115	G 1"	0,5
EHP-C-0100-250-100-AH00AAP00 (2)	10	250	100	236	-20/+80	35.3	1460	115	G 1"	0,5

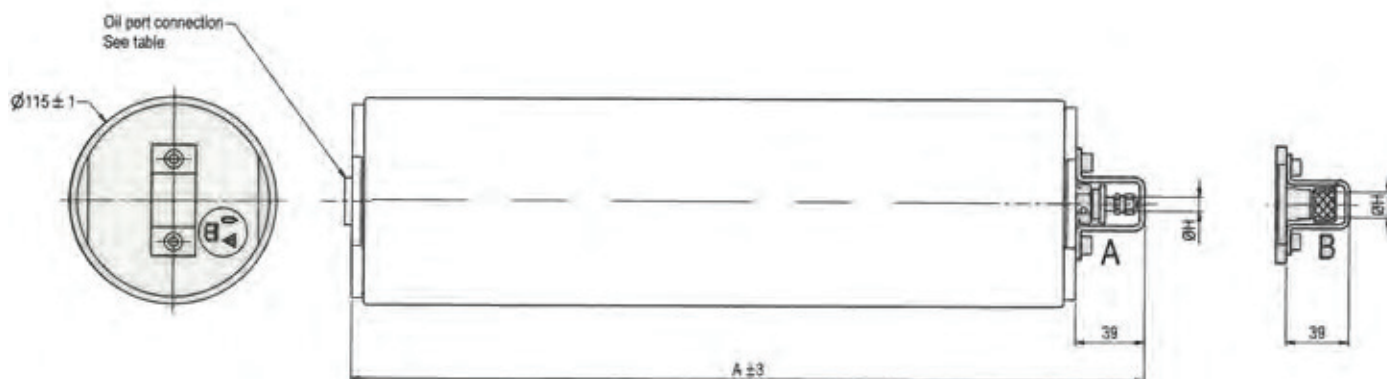

Above dimensions are in mm and are subject to manufacturing tolerances.

EHP Series 250 bar, 4 to 25 Litres, Ø 140

Standard version (Carbon steel/Wynseal for mineral oil, AQseal for other fluids) for mineral oils,
According to PED 97/23/EC, EN14359-2006

Part numbers, Dimensions

Most common configurations

Type Part number	Pre-charge			Wynseal Piston Kit	Without burst disc. Plugged connection
	1 - 109 bar	110 - 209 bar	210 - 300 bar	Part number	Model Part number
EHP-C-0040-250-140-AKAFABP00 (1) 9098-1604-AKAF-ABP00	751012	751020	751036	AQ seal 9782-140-185	Consult Division
EHP-C-0060-250-140-AKAFABP00 (2) 9098-1904-AKAF-ABP00	751015	751020	751036	AQ seal 9782-140-185	Consult Division
EHP-C-0080-250-140-AKAFABP00 (2) 9098-2004-AKAF-ABP00	751004	751022	751037	AQ seal 9782-140-185	Consult Division
EHP-C-0060-250-140-AKAF AAP00 (2) 9098-1904-AKAF-AAP00	751015	751020	751036	Wynseal 9782-140-001	Consult Division
EHP-C-0080-250-140-AKAF AAP00 (2) 9098-2004-AKAF-AAP00	751004	751022	751037	Wynseal 9782-140-001	Consult Division
EHP-C-0100-250-140-AKAF AAP00 (2) 9098-2104-AKAF-AAP00	751004	751022	751037	Wynseal 9782-140-001	Consult Division
EHP-C-0150-250-140-AKAF AAP00 (3) 9098-2304-AKAF-AAP00	751004	751022	751037	Wynseal 9782-140-001	Consult Division
EHP-C-0200-250-140-AKAF AAP00 (3) 9098-2604-AKAF-AAP00	751004	751022	751037	Wynseal 9782-140-001	Consult Division
EHP-C-0150-250-140-AF00AA000 (3) 9098-2304-AF00-AA000	751004	751022	751037	Wynseal 9782-140-001	-

CE Marked complies with group fluid 2 according to the PED 97/23/EC

- (1) Category II
(2) Category III
(3) Category IV

Type	Effective Gas vol. Litres	Max. Working pressure (PS) bar	Dia Bore	Max Flow Rate lt/min	Allowable Temperature °C	Weight kg	A max height	External øD max	Oil port connection	V m/s
EHP-C-0040-250-140-AKAFABP00 (1)	4	250	140	1846	-20/+150	35.2	470	160	G 1 1/2"	2
EHP-C-0060-250-140-AKAFABP00 (2)	6	250	140	1846	-20/+150	39.9	600	160	G 1 1/2"	2
EHP-C-0080-250-140-AKAFABP00 (2)	8	250	140	1846	-20/+150	44.7	730	160	G 1 1/2"	2
EHP-C-0060-250-140-AKAFAAP00 (2)	6	250	140	462	-20/+80	39.9	600	160	G 1 1/2"	0.5
EHP-C-0080-250-140-AKAFAAP00 (2)	8	250	140	462	-20/+80	44.7	730	160	G 1 1/2"	0.5
EHP-C-0100-250-140-AKAFAAP00 (2)	10	250	140	462	-20/+80	49.5	860	160	G 1 1/2"	0.5
EHP-C-0150-250-140-AKAFAAP00 (3)	15	250	140	462	-20/+80	61.5	1185	160	G 1 1/2"	0.5
EHP-C-0200-250-140-AKAFAAP00 (3)	20	250	140	462	-20/+80	72.8	1509	160	G 1 1/2"	0.5
EHP-C-0150-250-140-AF00AA000 (3)	15	250	140	462	-20/+80	61.5	1185	160	G 3/4"	0.5

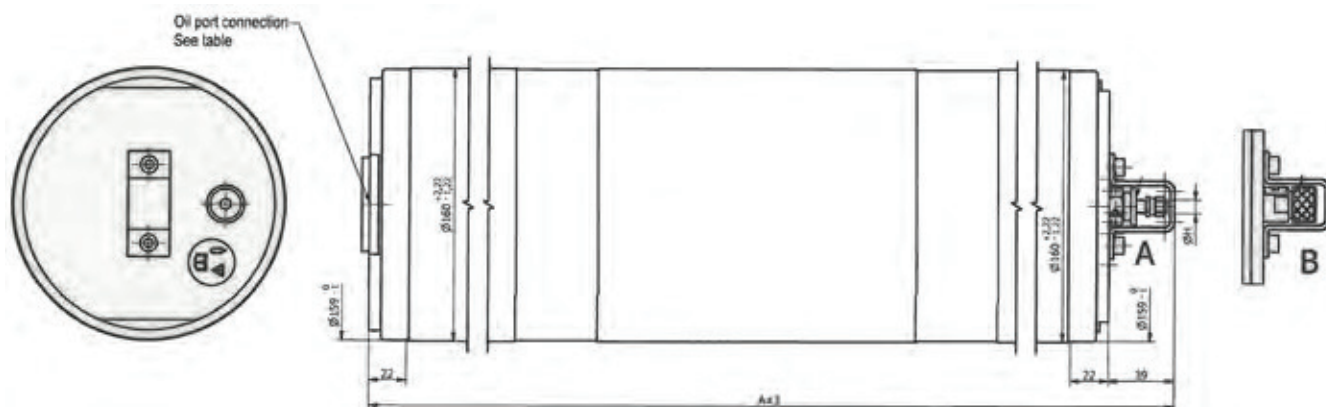

Above dimensions are in mm and are subject to manufacturing tolerances.

EHP Series 250 bar, 8 to 50 Litres, Ø 180

Standard version (**Carbon Steel** shell/seals for mineral oils) temperature from - 15° up to 100°C. Maximum Piston Speed 2 m/s. Suitable for Mineral based hydraulic fluids, Vegetable oils, Water Glycols. For other fluids please contact Parker Olaer. According to PED 97/23/EC, Fluid Group 1/2

Part numbers, Dimensions

Type	Part number	
EHP C 0080/250/180	815EHP0C00802518	
EHP C 0100/250/180	815EHP0C01002518	
EHP C 0150/250/180	815EHP0C01502518	
EHP C 0200/250/180	815EHP0C02002518	
EHP C 0300/250/180	815EHP0C03002518	
EHP C 0400/250/180	815EHP0C04002518	
EHP C 0500/250/180	815EHP0C05002518	

Type	Effective Gas vol. Litres	Design P bar	Weight kg	L mm	D mm	d mm	Max Fluid opening	Seal Kit
EHP C 0080/250/180	8	250	110	622	219.1	180	G1"	822000000011
EHP C 0100/250/180	10	250	120	700	219.1	180	G1"	822000000011
EHP C 0150/250/180	15	250	135	896	219.1	180	G1"	822000000011
EHP C 0200/250/180	20	250	160	1095	219.1	180	G1"	822000000011
EHP C 0300/250/180	30	250	190	1485	219.1	180	G1"	822000000011
EHP C 0400/250/180	40	250	230	1880	219.1	180	G1"	822000000011
EHP C 0500/250/180	50	250	270	2275	219.1	180	G1"	822000000011

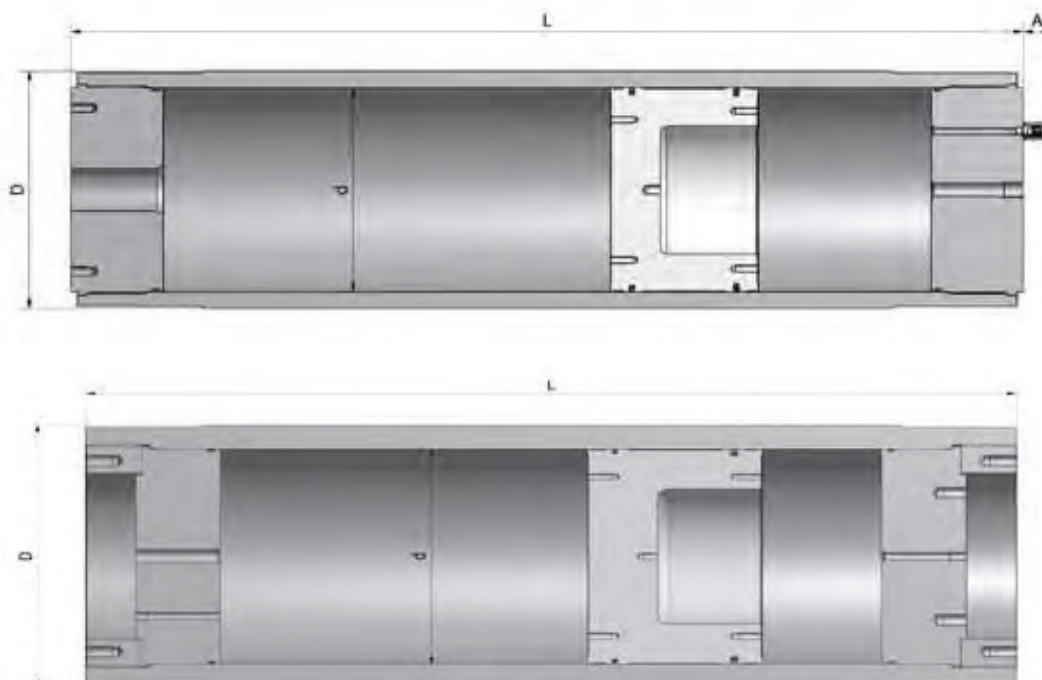

EHP Series 250 bar, 10 to 150 Litres, Ø 195

Standard version (**Stainless Steel** shell/seals for mineral oils) temperature from - 15° up to 100°C. Maximum Piston Speed 2 m/s. Suitable for Mineral based hydraulic fluids, Vegetable oils, Water Glycols. For other fluids please contact Parker Olaer. According to PED 97/23/EC, Fluid Group 1/2.

Part numbers, Dimensions

Type	Part number
EHP S 0100-250-195	815EHP0S0102519
EHP S 0200-250-195	815EHP0S0202519
EHP S 0300-250-195	815EHP0S0302519
EHP S 0400-250-195	815EHP0S0402519
EHP S 0500-250-195	815EHP0S0502519
EHP S 0600-250-195	815EHP0S0602519
EHP S 0700-250-195	815EHP0S0702519
EHP S 0800-250-195	815EHP0S0802519
EHP S 0900-250-195	815EHP0S0902519
EHP S 1000-250-195	815EHP0S1002519
EHP S 1500-250-195	815EHP0S1502519

Type	Effective Gas vol. Litres	Design P bar	Weight kg	L mm	D mm	d mm	Std Fluid opening	A mm	Seal Kit
EHP S 0100-250-195	10	250	150	645	243	195	G2"	45	8220000000020
EHP S 0200-250-195	20	250	199	980	243	195	G2"	45	8220000000020
EHP S 0300-250-195	30	250	249	1315	243	195	G2"	45	8220000000020
EHP S 0400-250-195	40	250	299	1650	243	195	G2"	45	8220000000020
EHP S 0500-250-195	50	250	348	1985	243	195	G2"	45	8220000000020
EHP S 0600-250-195	60	250	398	2320	243	195	G2"	45	8220000000020
EHP S 0700-250-195	70	250	447	2654	243	195	G2"	45	8220000000020
EHP S 0800-250-195	80	250	497	2989	243	195	G2"	45	8220000000020
EHP S 0900-250-195	90	250	546	3324	243	195	G2"	45	8220000000020
EHP S 1000-250-195	100	250	596	3659	243	195	G2"	45	8220000000020
EHP S 1500-250-195	150	250	844	5333	243	195	G2"	45	8220000000020

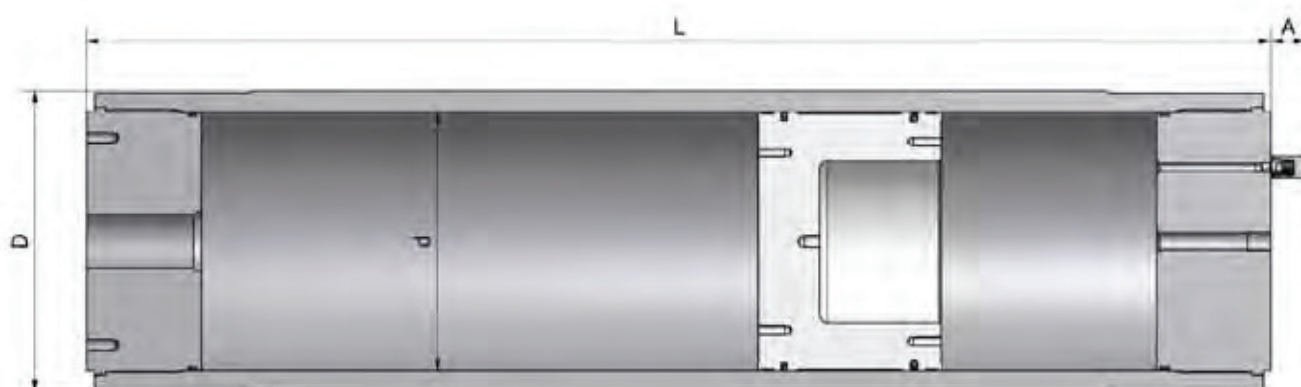

EHP Series 250 bar, 10 to 150 Litres, Ø 200

Standard version (**Carbon Steel** shell/seals for mineral oils) temperature from - 15° up to 100°C. Maximum Piston Speed 2 m/s. Suitable for Mineral based hydraulic fluids, Vegetable oils, Water Glycols. For other fluids please contact Parker Olaer. According to PED 97/23/EC, Fluid Group 1/2.

Part numbers, Dimensions

Type	Part number
EHP C 0100-250-200	815EHP0C0102520
EHP C 0200-250-200	815EHP0C0202520
EHP C 0300-250-200	815EHP0C0302520
EHP C 0350-250-200	815EHP0C0352520
EHP C 0400-250-200	815EHP0C0402520
EHP C 0500-250-200	815EHP0C0502520
EHP C 0750-250-200	815EHP0C0752520
EHP C 0800-250-200	815EHP0C0802520
EHP C 0900-250-200	815EHP0C0902520
EHP C 1000-250-200	815EHP0C1002520
EHP C 1500-250-200	815EHP0C1502520

Type	Effective Gas vol. Litres	Design P bar	Weight kg	L mm	D mm	d mm	Std Fluid opening	A mm	Seal Kit
EHP C 0100-250-200	10	250	87	585	230	200	G2"	45	8220000000023
EHP C 0200-250-200	20	250	110	903	230	200	G2"	45	8220000000023
EHP C 0300-250-200	30	250	133	1221	230	200	G2"	45	8220000000023
EHP C 0350-250-200	35	250	144	1321	230	200	G2"	45	8220000000023
EHP C 0400-250-200	40	250	156	1540	230	200	G2"	45	8220000000023
EHP C 0500-250-200	50	250	178	1858	230	200	G2"	45	8220000000023
EHP C 0750-250-200	75	250	236	2654	230	200	G2"	45	8220000000023
EHP C 0800-250-200	80	250	247	2813	230	200	G2"	45	8220000000023
EHP C 0900-250-200	90	250	270	3131	230	200	G2"	45	8220000000023
EHP C 1000-250-200	100	250	293	3450	230	200	G2"	45	8220000000023
EHP C 1500-250-200	150	250	407	5041	230	200	G2"	45	8220000000023

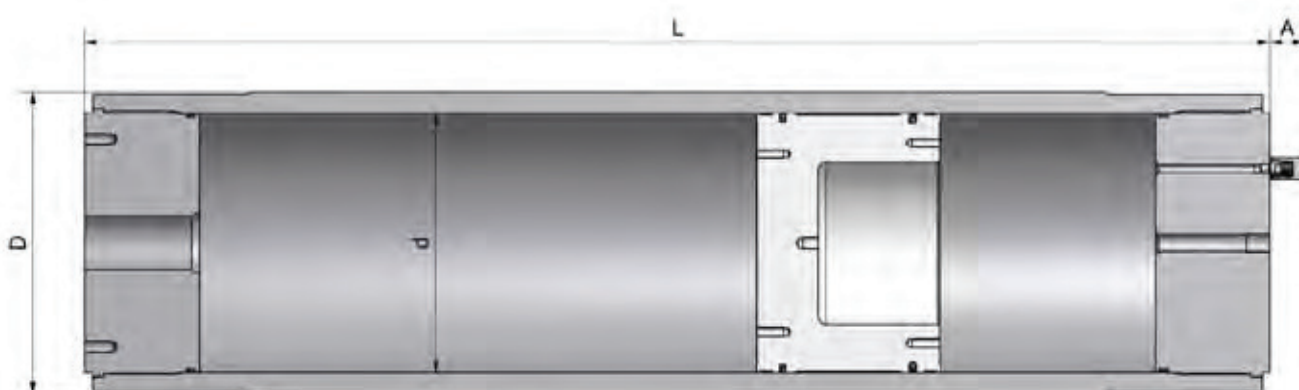

Piston Accumulators**EHP Series 250 bar, 25 to 200 Litres, Ø 250**

Standard version (**Carbon Steel** shell/seals for mineral oils) temperature from - 15° up to 100°C. Maximum Piston Speed 2 m/s. Suitable for Mineral based hydraulic fluids, Vegetable oils, Water Glycols. For other fluids please contact Parker Olaer. According to PED 97/23/EC, Fluid Group 1/2.

Part numbers, Dimensions

Type	Part number
EHP C 0250-250-250	815EHP0C0252525
EHP C 0300-250-250	815EHP0C0302525
EHP C 0400-250-250	815EHP0C0402525
EHP C 0500-250-250	815EHP0C0502525
EHP C 0600-250-250	815EHP0C0602525
EHP C 0700-250-250	815EHP0C0702525
EHP C 0800-250-250	815EHP0C0802525
EHP C 0900-250-250	815EHP0C0902525
EHP C 1000-250-250	815EHP0C1002525
EHP C 2000-250-250	815EHP0C2002525

Piston Accumulators

Type	Effective Gas vol. Litres	Design P bar	Weight kg	L mm	D mm	d mm	Std Fluid opening	A mm	Seal Kit
EHP C 0250-250-250	25	250	260	891	298.5	250	G2"	45	8220000000003
EHP C 0300-250-250	30	250	275	992	298.5	250	G2"	45	8220000000003
EHP C 0400-250-250	40	250	310	1196	298.5	250	G2"	45	8220000000003
EHP C 0500-250-250	50	250	345	1401	298.5	250	G2"	45	8220000000003
EHP C 0600-250-250	60	250	375	1606	298.5	250	G2"	45	8220000000003
EHP C 0700-250-250	70	250	410	1811	298.5	250	G2"	45	8220000000003
EHP C 0800-250-250	80	250	445	2011	298.5	250	G2"	45	8220000000003
EHP C 0900-250-250	90	250	475	2216	298.5	250	G2"	45	8220000000003
EHP C 1000-250-250	100	250	510	2421	298.5	250	G2"	45	8220000000003
EHP C 2000-250-250	200	250	660	4458	298.5	250	G2"	45	8220000000003

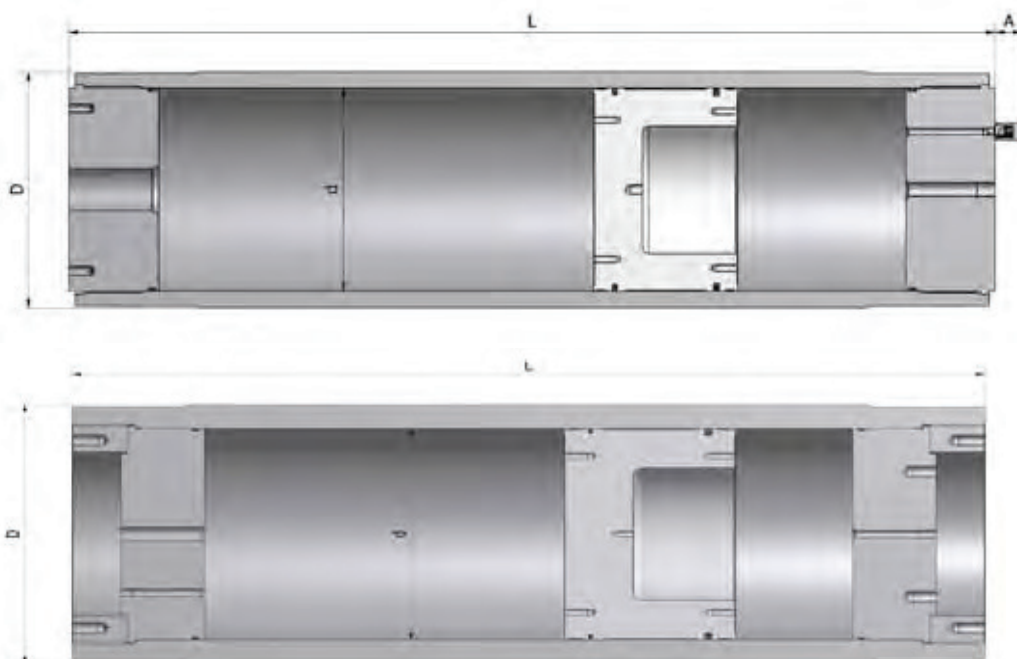

EHP Series 250 bar, 30 to 500 Litres, Ø 350

Standard version (**Carbon Steel** shell/seals for mineral oils) temperature from - 15° up to 100°C. Maximum Piston Speed 2 m/s. Suitable for Mineral based hydraulic fluids, Vegetable oils, Water Glycols. For other fluids please contact Parker Olaer. According to PED 97/23/EC, Fluid Group 1/2.

Part numbers, Dimensions

Type	Part number
EHP C 0300-250-350	815EHP0C0302535
EHP C 0400-250-350	815EHP0C0402535
EHP C 0500-250-350	815EHP0C0502535
EHP C 1000-250-350	815EHP0C1002535
EHP C 1500-250-350	815EHP0C1502535
EHP C 2000-250-350	815EHP0C2002535
EHP C 2500-250-350	815EHP0C2502535
EHP C 3000-250-350	815EHP0C3002535
EHP C 3500-250-350	815EHP0C3502535
EHP C 4000-250-350	815EHP0C4002535
EHP C 4500-250-350	815EHP0C4502535
EHP C 5000-250-350	815EHP0C5002535

Type	Effective Gas vol. Litres	Design P bar	Weight kg	L mm	D mm	d mm	Std Fluid opening	A mm	Seal Kit
EHP C 0300-250-350	30	250	445	818	406.4	350	G2"	45	8220000000003
EHP C 0400-250-350	40	250	472	922	406.4	350	G2"	45	8220000000003
EHP C 0500-250-350	50	250	500	1026	406.4	350	G2"	45	8220000000003
EHP C 1000-250-350	100	250	637	1546	406.4	350	G2"	45	8220000000003
EHP C 1500-250-350	150	250	772	2066	406.4	350	G2"	45	8220000000003
EHP C 2000-250-350	200	250	912	2586	406.4	350	G2"	45	8220000000003
EHP C 2500-250-350	250	250	1048	3106	406.4	350	G2"	45	8220000000003
EHP C 3000-250-350	300	250	1185	3626	406.4	350	G2"	45	8220000000003
EHP C 3500-250-350	350	250	1322	4146	406.4	350	G2"	45	8220000000003
EHP C 4000-250-350	400	250	1429	4664	406.4	350	G2"	45	8220000000003
EHP C 4500-250-350	450	250	1565	5183	406.4	350	G2"	45	8220000000003
EHP C 5000-250-350	500	250	1702	5703	406.4	350	G2"	45	8220000000003

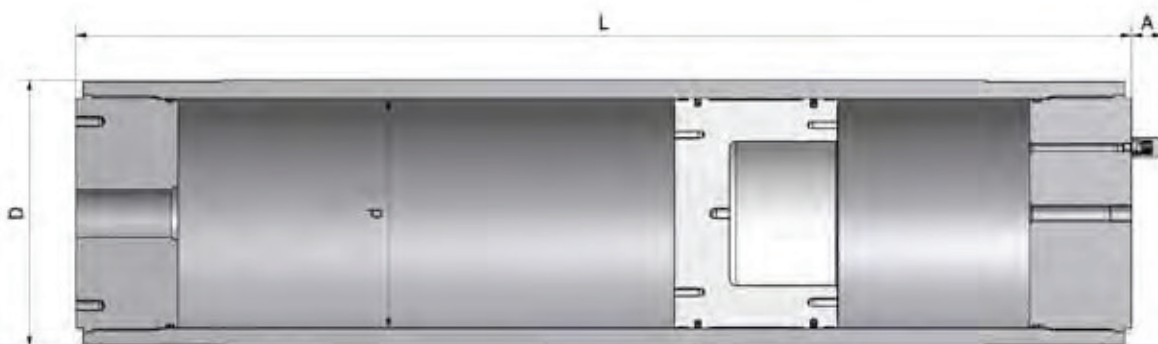

EHP Series 350 bar, 2 to 10 Litres, Ø 100

Standard version (**Carbon Steel** shell/seals for mineral oils) temperature from / 15° up to 100°C. Maximum Piston Speed 2 m/s. Suitable for Mineral based hydraulic fluids, Vegetable oils, Water Glycols. For other fluids please contact Parker Olaer. According to PED 97/23/EC, ASME VIII Div.1 Design, Fluid Group 1/2

Part numbers, Dimensions

Type	Part number
EHP C 0020-350-100	815EHP0C00023510
EHP C 0030-350-100	815EHP0C00033510
EHP C 0040-350-100	815EHP0C00043510
EHP C 0050-350-100	815EHP0C00053510
EHP C 0060-350-100	815EHP0C00063510
EHP C 0070-350-100	815EHP0C00073510
EHP C 0080-350-100	815EHP0C00083510
EHP C 0090-350-100	815EHP0C00093510
EHP C 0100-350-100	815EHP0C00103510

Type	Effective Gas vol. Litres	Design P bar	Weight kg	L mm	D mm	d mm	Max Fluid opening	Seal Kit
EHP C 0020-350-100	2	350	37	475	140	100	G1"	8220000000024
EHP C 0030-350-100	3	350	45	602	140	100	G1"	8220000000024
EHP C 0040-350-100	4	350	52	729	140	100	G1"	8220000000024
EHP C 0050-350-100	5	350	60	857	140	100	G1"	8220000000024
EHP C 0060-350-100	6	350	67	984	140	100	G1"	8220000000024
EHP C 0070-350-100	7	350	75	1111	140	100	G1"	8220000000024
EHP C 0080-350-100	8	350	83	1239	140	100	G1"	8220000000024
EHP C 0090-350-100	9	350	90	1366	140	100	G1"	8220000000024
EHP C 0100-350-100	10	350	98	1493	140	100	G1"	8220000000024

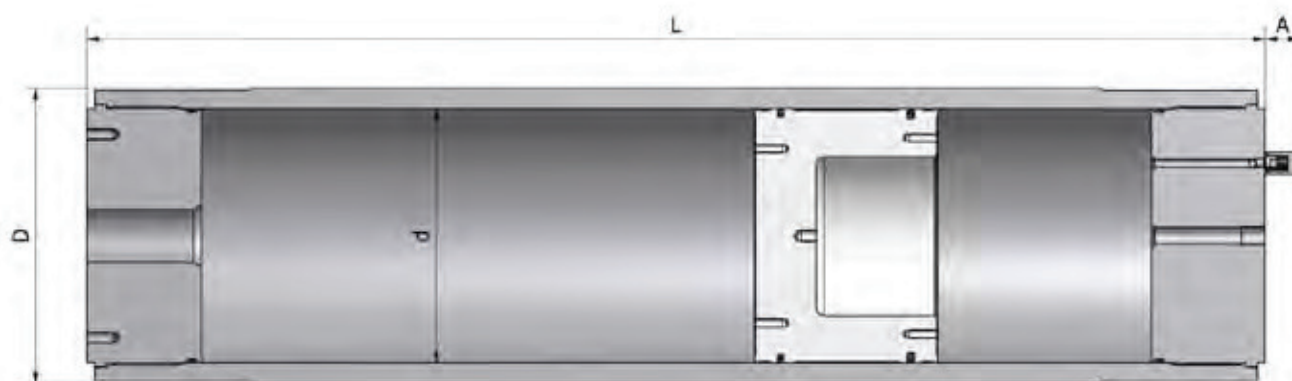

EHP Series 350 bar, 8 to 50 Litres, Ø 180

Standard version (**Carbon Steel** shell/seals for mineral oils) temperature from - 15° up to 100°C. Maximum Piston Speed 2 m/s. Suitable for Mineral based hydraulic fluids, Vegetable oils, Water Glycols. For other fluids please contact Parker Olaer According to PED 97/23/EC, Fluid Group 1/2.

Part numbers, Dimensions

Type	Part number
EHP C 0080-350-180	815EHP0C0083518
EHP C 0100-350-180	815EHP0C0103518
EHP C 0150-350-180	815EHP0C0153518
EHP C 0200-350-180	815EHP0C0203518
EHP C 0300-350-180	815EHP0C0303518
EHP C 0400-350-180	815EHP0C0403518
EHP C 0500-350-180	815EHP0C0503518

Type	Effective Gas vol. Litres	Design P bar	Weight kg	L mm	D mm	d mm	Max Fluid opening	Seal Kit
EHP C 0080-350-180	8	350	130	646	229	180	G2"	8220000000011
EHP C 0100-350-180	10	350	140	724	229	180	G2"	8220000000011
EHP C 0150-350-180	15	350	165	920	229	180	G2"	8220000000011
EHP C 0200-350-180	20	350	185	1116	229	180	G2"	8220000000011
EHP C 0300-350-180	30	350	235	1510	229	180	G2"	8220000000011
EHP C 0400-350-180	40	350	285	1902	229	180	G2"	8220000000011
EHP C 0500-350-180	50	350	335	2295	229	180	G2"	8220000000011

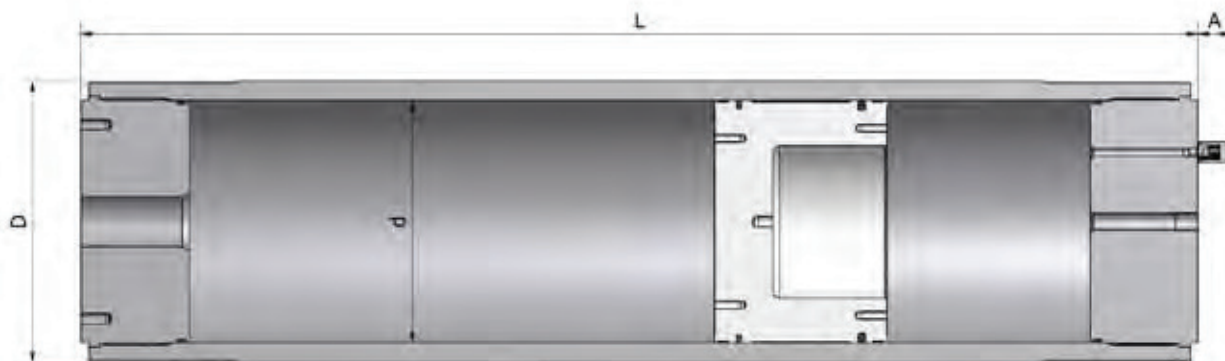

EHP Series 350 bar, 25 to 200 Litres, Ø 250

Standard version (**Carbon Steel** shell/seals for mineral oils) temperature from - 15° up to 100°C. Maximum Piston Speed 2 m/s. Suitable for Mineral based hydraulic fluids, Vegetable oils, Water Glycols. For other fluids please contact Parker Olaer. According to PED 97/23/EC, Fluid Group 1/2.

Part numbers, Dimensions

Type	Part number
EHP C 0250-350-250	815EHP0C0253525
EHP C 0300-350-250	815EHP0C0303525
EHP C 0400-350-250	815EHP0C0403525
EHP C 0500-350-250	815EHP0C0503525
EHP C 0600-350-250	815EHP0C0603525
EHP C 0700-350-250	815EHP0C0703525
EHP C 0800-350-250	815EHP0C0803525
EHP C 0900-350-250	815EHP0C0903525
EHP C 0950-350-250	815EHP0C0953525
EHP C 1000-350-250	815EHP0C1003525

Type	Effective Gas vol. Litres	Design P bar	Weight kg	L mm	D mm	d mm	Std Fluid opening	A mm	Seal Kit
EHP C 0250-350-250	25	350	355	914	323.8	250	G2"	45	8220000000003
EHP C 0300-350-250	30	350	380	1016	323.8	250	G2"	45	8220000000003
EHP C 0400-350-250	40	350	435	1220	323.8	250	G2"	45	8220000000003
EHP C 0500-350-250	50	350	485	1423	323.8	250	G2"	45	8220000000003
EHP C 0600-350-250	60	350	510	1627	323.8	250	G2"	45	8220000000003
EHP C 0700-350-250	70	350	595	1830	323.8	250	G2"	45	8220000000003
EHP C 0800-350-250	80	350	645	2035	323.8	250	G2"	45	8220000000003
EHP C 0900-350-250	90	350	700	2238	323.8	250	G2"	45	8220000000003
EHP C 0950-350-250	100	350	725	2340	323.8	250	G2"	45	8220000000003
EHP C 1000-350-250	200	350	750	2442	323.8	250	G2"	45	8220000000003

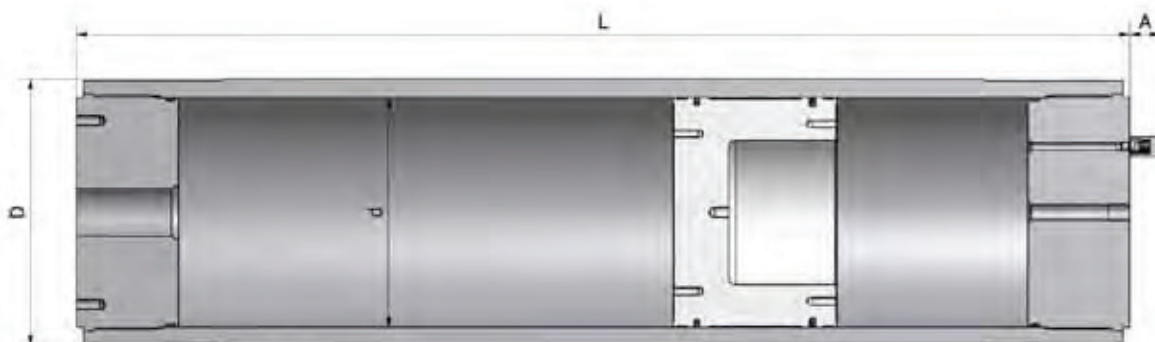

EHP Series 350 bar, 30 to 350 Litres, Ø 350

Standard version (**Carbon Steel** shell/seals for mineral oils) temperature from - 15° up to 100°C. Maximum Piston Speed 2 m/s. Suitable for Mineral based hydraulic fluids, Vegetable oils, Water Glycols. For other fluids please contact Parker Olaer. According to PED 97/23/EC, Fluid Group 1/2

Part numbers, Dimensions

Type	Part number
EHP C 0300/350/350	815EHP0C03003535
EHP C 0400/350/350	815EHP0C04003535
EHP C 0500/350/350	815EHP0C05003535
EHP C 0600/350/350	815EHP0C06003535
EHP C 0700/350/350	815EHP0C07003535
EHP C 0800/350/350	815EHP0C08003535
EHP C 0900/350/350	815EHP0C09003535
EHP C 1000/350/350	815EHP0C10003535
EHP C 1500/350/350	815EHP0C15003535
EHP C 2000/350/350	815EHP0C20003535
EHP C 2500/350/350	815EHP0C25003535
EHP C 3000/350/350	815EHP0C30003535
EHP C 3500/350/350	815EHP0C35003535

Type	Effective Gas vol. Litres	Design P bar	Weight kg	L mm	D mm	d mm	Max Fluid opening	Seal Kit
EHP C 0300/350/350	30	350	775	842	457.2	350	G5"	8220000000002
EHP C 0400/350/350	40	350	830	946	457.2	350	G5"	8220000000002
EHP C 0500/350/350	50	350	885	1050	457.2	350	G5"	8220000000002
EHP C 0600/350/350	60	350	940	1154	457.2	350	G5"	8220000000002
EHP C 0700/350/350	70	350	995	1259	457.2	350	G5"	8220000000002
EHP C 0800/350/350	80	350	1050	1362	457.2	350	G5"	8220000000002
EHP C 0900/350/350	90	350	1110	1466	457.2	350	G5"	8220000000002
EHP C 1000/350/350	100	350	1165	1570	457.2	350	G5"	8220000000002
EHP C 1500/350/350	150	350	1440	2090	457.2	350	G5"	8220000000002
EHP C 2000/350/350	200	350	1720	2610	457.2	350	G5"	8220000000002
EHP C 2500/350/350	250	350	1995	3130	457.2	350	G5"	8220000000002
EHP C 3000/350/350	300	350	2275	3650	457.2	350	G5"	8220000000002
EHP C 3500/350/350	350	350	2550	4170	457.2	350	G5"	8220000000002

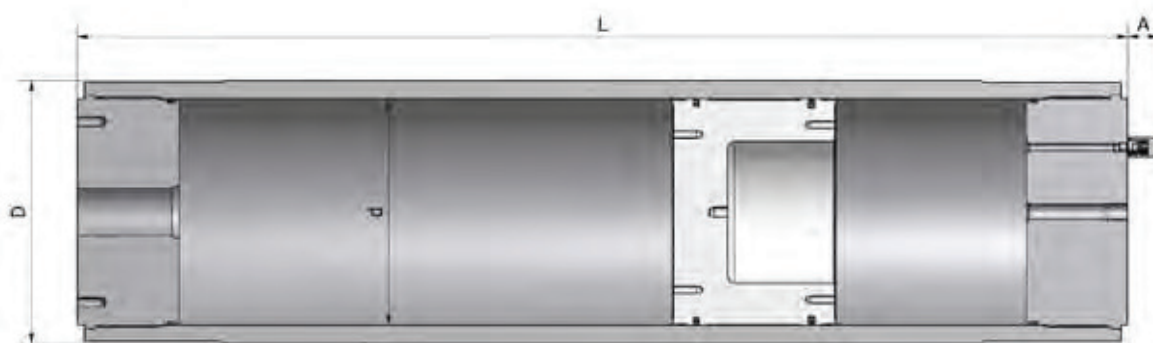

Regulations for EHP Piston Accumulators

		Data			Certification (*)								
		øl mm	Material	Design P bar	PED 97/23/EC	ASME VIII Div.1	CRN (Canada)	AS 1210 (Australia)	SELO (Cina)	NR13 (Brasile)	ARH (Algeria)	DOSH (Malaysia)	MOM (Singapore)
Piston Accumulators EHP / IHP	EHP / IHP C xxxx-350-100	100	CS	350	●	●	○	○	-	○	○	○	○
	EHP / IHP C xxxx-250-180	180	CS	250	●	●	○	○	○	○	○	○	○
	EHP / IHP C xxxx-350-180	180	CS	350	●	●	○	○	○	○	○	○	○
	EHP / IHP S xxxx-250-195	195	SS	250	●	●	○	○	-	○	○	○	○
	EHP / IHP C xxxx-250-200	200	CS	250	●	●	○	○	-	○	○	○	○
	EHP / IHP C xxxx-250-250	250	CS	250	●	●	○	○	○	○	○	○	○
	EHP / IHP C xxxx-350-250	250	CS	350	●	●	○	○	○	○	○	○	○
	EHP / IHP C xxxx-220-350	350	CS	220	●	●	○	○	○	○	○	○	○
	EHP / IHP C xxxx-250-350	350	CS	250	●	●	○	○	-	○	○	○	○
	EHP / IHP C xxxx-350-350	350	CS	350	●	●	○	○	○	○	○	○	○
	EHP(G) / IHP(G) S xxxx-207-360	360	SS	207	●	●	○	○	-	○	○	○	○
	EHP(G) / IHP(G) C xxxx-220-540	540	CS	220	●	●	○	○	-	○	○	○	○
	EHP C xxxx 250-80	80	CS	250	●	-	-	-	●	○	○	○	○
	EHP C xxxx 250-100	100	CS	250	●	-	-	-	●	○	○	○	○
	EHP C xxxx 250-140	140	CS	250	●	-	-	-	●	○	○	○	○

- Available
- Available on request
- Not Available
- (*) Design P could change according Certification/Design Code

	Certification (*)							Design Code (*)		
	Ri.N.A.	ABS	DNV	Bureau Veritas	Lloyd's Register	RT (Russia- Belorussia- Kazakhstan)	EN 14359 EN 13445	ASME VIII Div.1	AD Merkblatt	AS 1210
	○	○	○	○	○	●	●	●	○	○
	●	○	○	○	○	●	○	○	●	○
	○	○	○	○	○	●	○	○	●	○
	○	○	○	○	○	●	●	○	○	○
	○	○	○	○	○	●	●	○	○	○
	●	○	○	○	○	●	○	○	●	○
	○	○	○	○	○	●	○	○	●	○
	●	○	○	○	○	●	○	○	●	○
	○	○	○	○	○	●	●	○	○	○
	○	○	○	○	○	●	○	○	●	○
	○	○	○	○	○	●	●	○	○	○
	○	○	○	○	○	●	○	○	●	○
	○	○	○	○	○	●	●	○	○	○
	-	●	●	○	○	●	●	-	-	-
	-	●	●	○	○	●	●	-	-	-
	-	●	●	○	○	●	●	-	-	-

This table is giving an indication of approval availability for the range of products. Availability is to be confirmed for each approval, in particular the pressure rating and the allowable working temperatures.

Piston Accumulators

A Series: How to order a Piston Accumulator

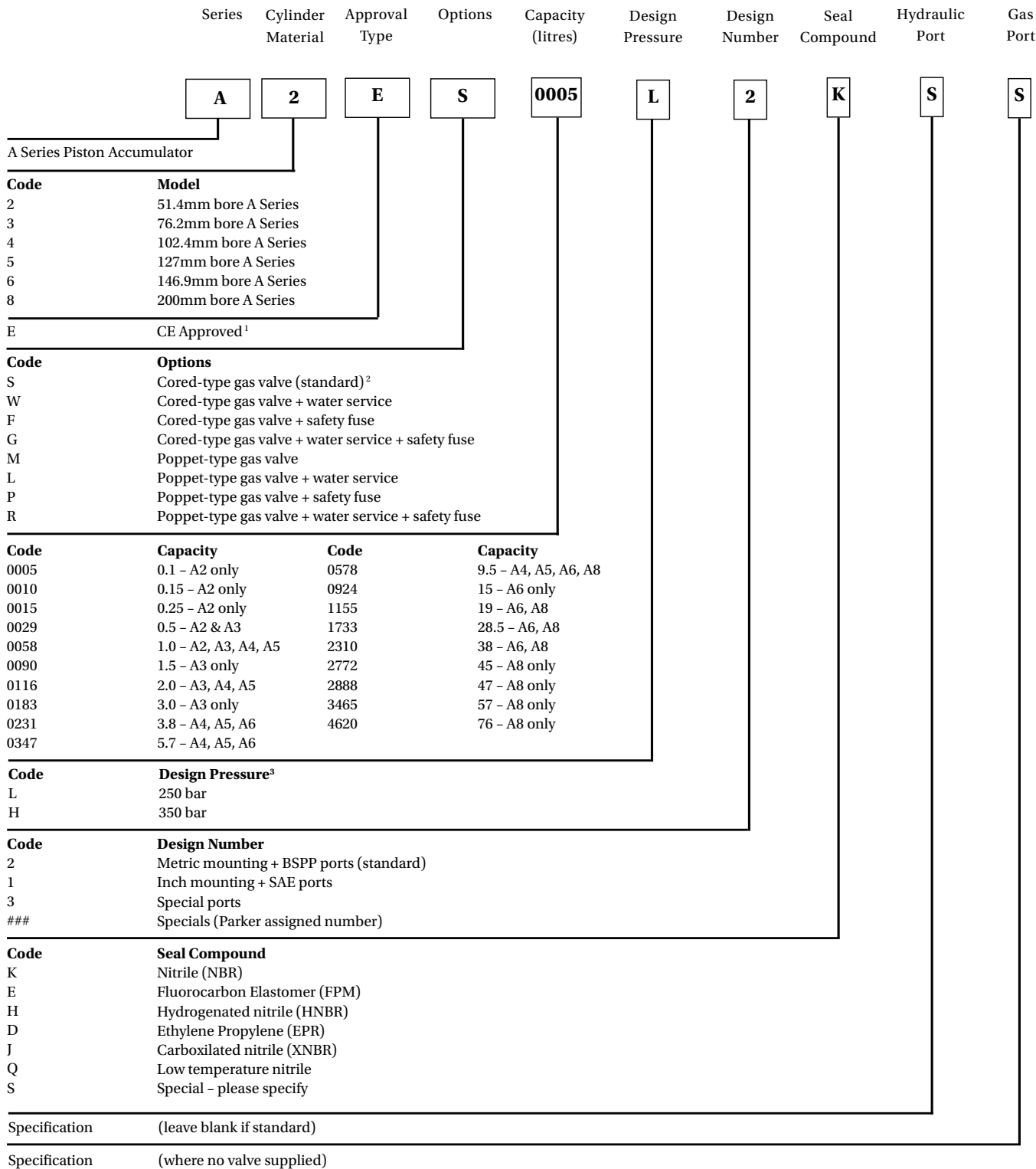

¹ Other approvals are available to order - please consult Parker.

² Where a gas port is specified, no gas valve will be supplied.

³ For other pressure ratings, please consult Parker.

A Series 250 bar, Volume 0.5 to 300 Litres

Standard version, Nitrile Seals, CE

Part numbers, Dimensions

Bore	Volume (Litres)	Port	Part number
50 mm	0.5	G3/4"	A2ES0029L2K
50 mm	1	G3/4"	A2ES0058L2K
75 mm	1.5	G3/4"	A3ES0090L2K
75 mm	2	G3/4"	A3ES0116L2K
75 mm	3	G3/4"	A3ES0183L2K
100 mm	4	G1"	A4ES0231L2K
100 mm	6	G1"	A4ES0347L2K
100 mm	10	G1"	A4ES0578L2K
125 mm	4	G1"	A5ES0231L2K
125 mm	6	G1"	A5ES0347L2K
125 mm	10	G1"	A5ES0578L2K
150 mm	8	G1 1/2"	A6ES0488L2K
150 mm	10	G1 1/2"	A6ES0578L2K
150 mm	15	G1 1/2"	A6ES0924L2K
150 mm	20	G1 1/2"	A6ES1155L2K
150 mm	30	G1 1/2"	A6ES1733L2K
150 mm	40	G1 1/2"	A6ES2310L2K
200 mm	40	G2"	A8ES2310L2K
200 mm	45	G2"	A8ES2772L2K
200 mm	57	G2"	A8ES3465L2K
200 mm	76	G2"	A8ES4620L2K
180 mm	40		AP180EM040L2K
180 mm	50		AP180EM050L2K
180 mm	60		AP180EM060L2K
180 mm	80		AP180EM080L2K
250 mm	50		AP250EM050L2K
250 mm	80		AP250EM080L2K
250 mm	100		AP250EM100L2K
250 mm	125		AP250EM125L2K
250 mm	150		AP250EM150L2K
360 mm	100		AP360EM100L2K
360 mm	150		AP360EM150L2K
360 mm	200		AP360EM200L2K
360 mm	250		AP360EM250L2K
360 mm	300		AP360EM300L2K

Volumes are nominal

AP type includes Heavy duty Gas Valve

AP Series: How to order a Piston Accumulator

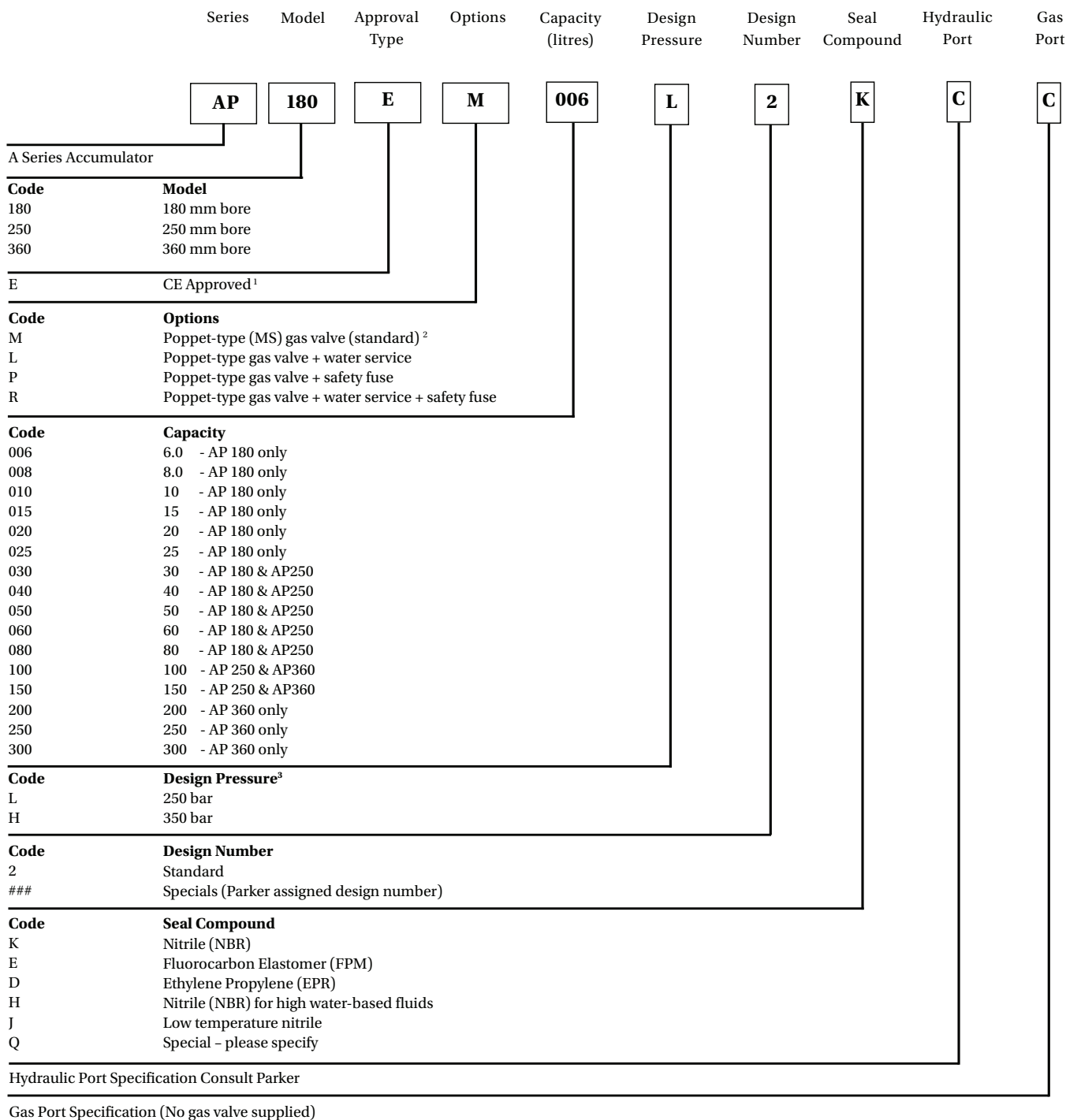

¹ Other approvals are available to order - please consult Parker.

² Where a gas port is specified, no gas valve will be supplied.

³ For other pressure ratings and for operating temperatures above 80 °C, please consult Parker.

AP Series 350 bar, 0.1 to 150 Litres

Standard version, Nitrile Seals, CE

Part numbers, Dimensions

Bore	Volume (Litres)	Port	Part number
50 mm	0.1	G3/4"	A2ES0005H2K
50 mm	0.5	G3/4"	A2ES0029H2K
50 mm	0.75	G3/4"	A2ES0045H2K
50 mm	1	G3/4"	A2ES0058H2K
75 mm	1.5	G3/4"	A3ES0090H2K
75 mm	2	G3/4"	A3ES0116H2K
75 mm	3	G3/4"	A3ES0183H2K
100 mm	4	G1"	A4ES0231H2K
100 mm	6	G1"	A4ES0347H2K
100 mm	10	G1"	A4ES0578H2K
200 mm	8	G11/2"	A6ES0488H2K
200 mm	10	G11/2"	A6ES0578H2K
200 mm	15	G11/2"	A6ES0924H2K
200 mm	20	G11/2"	A6ES1155H2K
200 mm	30	G11/2"	A6ES1733H2K
200 mm	40	G11/2"	A6ES2310H2K
180 mm	40		AP180EM040L2K
180 mm	50		AP180EM050L2K
180 mm	60		AP180EM060L2K
180 mm	80		AP180EM080L2K
250 mm	50		AP250EM050L2K
250 mm	80		AP250EM080L2K
250 mm	100		AP250EM100L2K
250 mm	125		AP250EM125L2K
250 mm	150		AP250EM150L2K
360 mm	100		AP360EM100L2K
360 mm	150		AP360EM150L2K

Volumes are nominal

AP type includes Heavy duty Gas Valve

ACP Series: How to order a Piston Accumulator

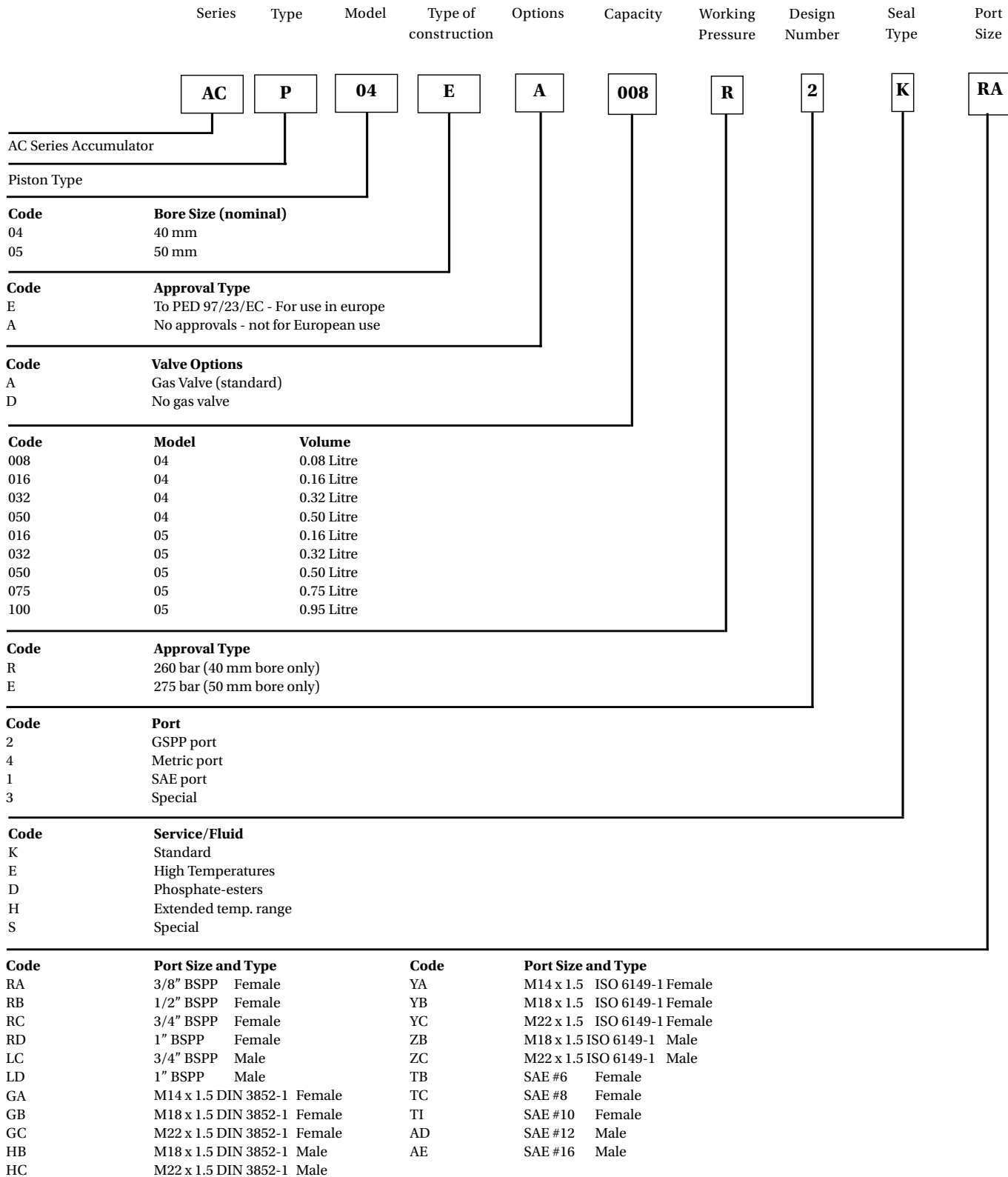

ACP Series 275 bar (260 bar), 0.08 to 8 Litres

Standard version, Nitrile Seals, CE

Part numbers, Dimensions

Bore	Volume (Litres)	Port	Part number
40 mm	0.08 (260 bar)	G3/8"	ACP04EA008R2KRA
40 mm	0.16 (260 bar)	G3/8"	ACP04EA016R2KRA
40 mm	0.32 (260 bar)	G3/8"	ACP04EA032R2KRA
50 mm	0.16	G1/2"	ACP05EA016E2KRB
50 mm	0.32	G1/2"	ACP05EA032E2KRB
50 mm	0.50	G1/2"	ACP05EA050E2KRB
50 mm	0.75	G1/2"	ACP05EA075E1KRB
50 mm	1	G1/2"	ACP05EA100E1KRB
50 mm	1.5	G1/2"	ACP05EA150E1KRB
50 mm	2	G1/2"	ACP05EA200E1KRB
80 mm	0.32	G3/4"	ACP08EA032E2KRC
80 mm	0.50	G3/4"	ACP08EA050E1KRC
80 mm	0.75	G3/4"	ACP08EA075E1KRC
80 mm	1	G3/4"	ACP08EA100E1KRC
80 mm	1.5	G3/4"	ACP08EA050E1KRC
80 mm	2	G3/4"	ACP08EA050E1KRC
80 mm	3	G3/4"	ACP08EA050E1KRC
100 mm	0.75	G1"	ACP10EA075E1KRD
100 mm	1	G1"	ACP10EA100E1KRD
100 mm	1.5	G1"	ACP10EA150E1KRD
100 mm	2	G1"	ACP10EA200E1KRD
100 mm	3	G1"	ACP10EA300E1KRD
100 mm	4	G1"	ACP10EA400E1KRD
100 mm	6	G1"	ACP10EA600E1KRD
100 mm	8	G1"	ACP10EA800E1KRD

Volumes are nominal

Attenuators

General information Attenuators

To attenuate the pressure pulses by at least 20 dB over a wide frequency range, Olaer produces high-frequency hydraulic attenuators with models ranging from 170 to 3000 Hz, in addition to its range of accumulators (up to 300 Hz).

The performance obtained with the attenuators reduces very substantially the fluctuations of high-frequency hydraulic pressure (see diagrams 1 and 2).

Curves 3 and 4 show firstly a typical attenuation curve (in dB) specific to each model of muffler, indicating the attenuation levels of the pressure pulses as a function, of the frequencies to be filtered, and secondly an example of the amplitude spectra of a pump with and without a muffler, which reduces the pulses from 217 dB to 190 dB.

Without Hydraulic Attenuators

With Hydraulic Attenuators

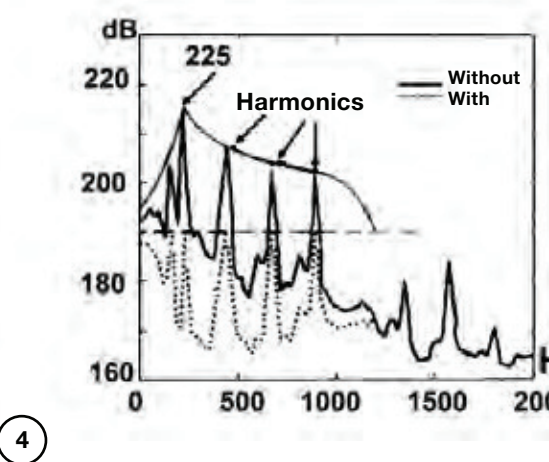
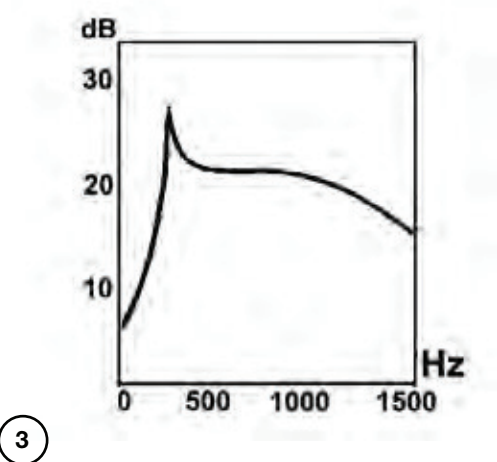
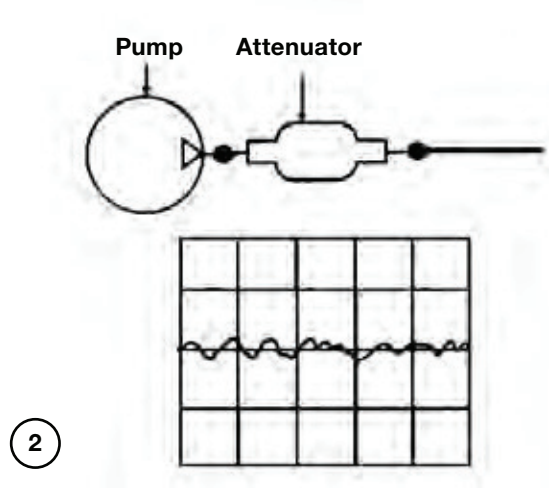
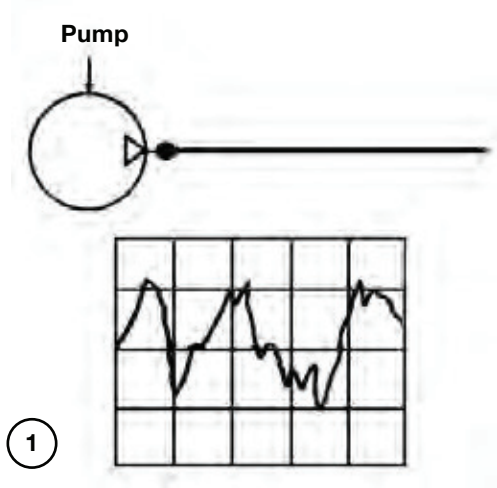

Attenuators

SH Series: How to order a Attenuator

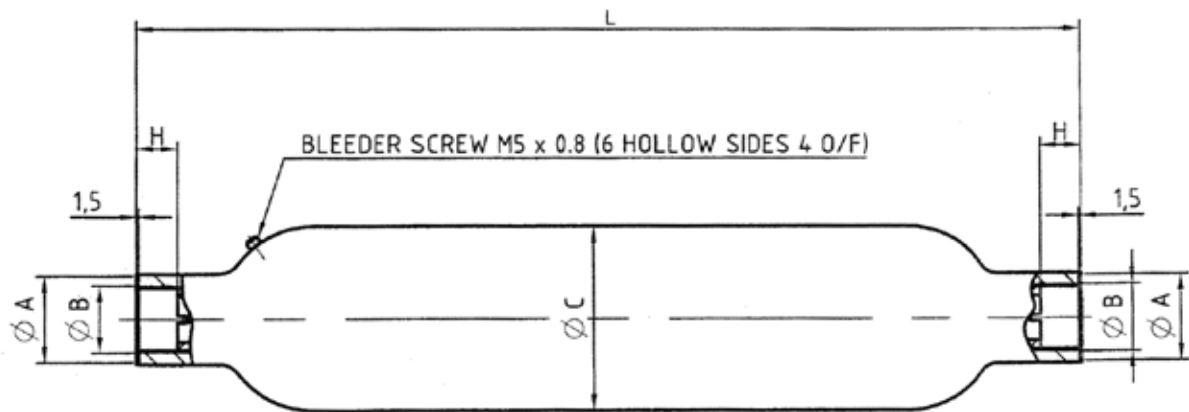
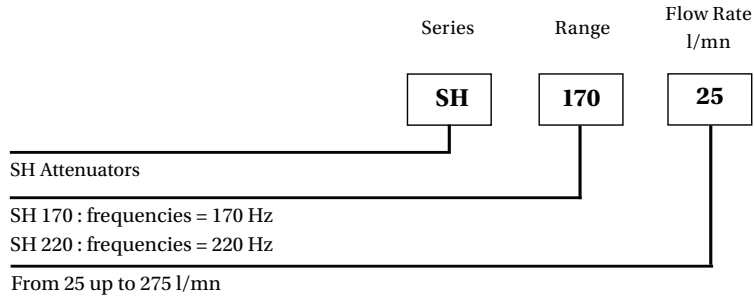

Attenuators SH Series 350 bar

Standard version (Carbon Steel shell) for allowable temperature from - 40° up to 175°C

According to PED 97/23/EC article 9 2.2. Fluid group 2

Part numbers, Accessories, Dimensions

Type	Part number	Clamps
		Model (quantity)
		Part number
SH 170-25	60045400100	E95 20250803648
SH 170-50	60045400100	E95 20250803648
SH 170-75	60045100100	E114 20251003648
SH 170-100	60044900100	E114 20251003648
SH 170-125	60045000100	E114 20251003648
SH 170-175	60044600100	E114 20251003648
SH 170-275	60045200100	E114 20251003648
SH 220-25	60045300100	E95 20250803648
SH 220-50	60043800100	E95 20250803648
SH 220-75	60045600100	E95 20250803648
SH 220-100	60045700100	E95 20250803648
SH 220-125	60045800100	E95 20250803648
SH 220-175	60044700100	E114 20251003648
SH 220-275	60044500100	E114 20251003648

Type	Volume Litres	Max. Working pressure (PS) bar	Max Flow Rate lt/min	Weight kg	Dimensions in mm				
					L max Height	øA for Bonded Seal	øB Gas Cyl.	øc	H mini
SH 170-25	1.5	350	25	5.8	462	35.3	3/4"	90	18
SH 170-50	2.2	350	50	7.3	590	35.3	3/4"	90	18
SH 170-75	3.4	350	75	12	597	54	1 1/4"	114	22
SH 170-100	3.4	350	100	12	597	54	1 1/4"	114	22
SH 170-125	4.6	350	125	15	749	54	1 1/4"	114	22
SH 170-175	4.6	350	170	15	749	54	1 1/4"	114	22
SH 170-275	4.6	350	275	15	749	54	1 1/4"	114	22
SH 220-25	1.2	350	25	5.2	386	35.3	3/4"	90	18
SH 220-50	1.5	350	50	5.8	462	35.3	3/4"	90	18
SH 220-75	1.5	350	75	5.8	462	35.3	3/4"	90	18
SH 220-100	2.2	350	100	7.4	590	35.3	3/4"	90	18
SH 220-125	2.2	350	125	7.4	590	35.3	3/4"	90	18
SH 220-175	3.4	350	175	12	597	54	1 1/4"	114	22
SH 220-275	3.4	350	275	12	597	54	1 1/4"	114	22

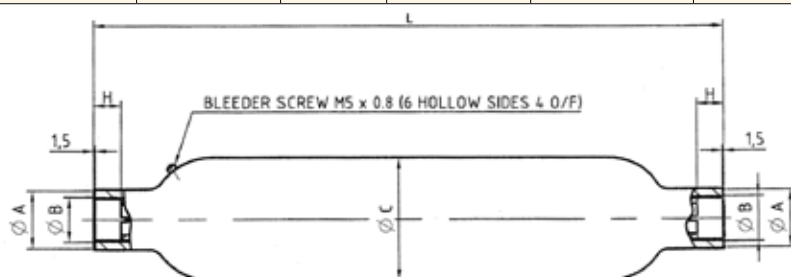

General Information Diaphragm Accumulator

Operation of the Olaer gas loaded diaphragm accumulator is based on the considerable difference in compressibility between a gas and a liquid, enabling a large quantity of energy to be stored in an extremely compact form. This enables a liquid under pressure to be accumulated, stored and recovered at any time.

The adaptation of a hydraulic shock absorber made up of a diaphragm accumulator improves driver comfort and offers immediate response times when driving over obstacles and the same flexibility for variable operating conditions.

0 < speed < 50 kph

3.5 < load variation < 100%

Identical flexibility depending on your use.

The same EC pressure directive (PED) compliant accumulator can be used in over 35 destination countries, thus facilitating their free movement.

The technical characteristics are as follows:

Minimum/maximum temperature allowable (° Celsius) :

- 20/+80 for standard nitrile elastomers for models between 0.5 < V < 1.4 Litre
- 10/+80 for standard nitrile elastomers for models ≥ 2 Litres and < 0.32 Litre
- 35/+80 for hydrin elastomers

Materials : carbon steel or stainless steel, nitrile or hydrin diaphragm, for other constructions: consult Parker Olaer.

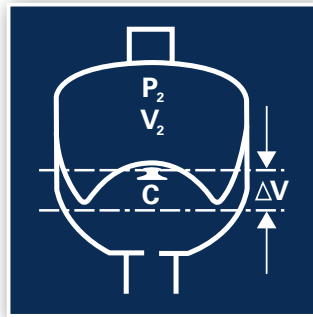
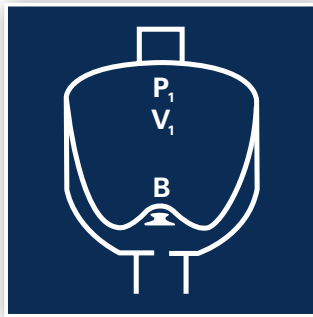
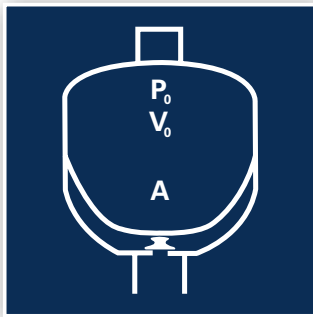

- V0** = Capacity in nitrogen of the accumulator
- V1** = Gas volume at the minimum hydraulic pressure
- V2** = Gas volume at the maximum hydraulic pressure
- ΔV** = Returned and/or stored volume of working fluid between P1 and P2
- P0** = Initial preload of the accumulator
- P1** = Gas pressure at the minimum hydraulic pressure
- P2** = Gas pressure at the maximum hydraulic pressure

A - The diaphragm is in the Pre-charge position, which means that it is only filled with nitrogen. The knob closes the hydraulic orifice and prevents the destruction of the diaphragm.

B - Position at the minimum operating pressure : there must be a certain amount of fluid between the diaphragm and the hydraulic orifice, such that the knob does not close the hydraulic orifice. Thus, P0 must always be < P1.

C - Position at the maximum operating pressure: the volume change Δ V between the minimum and maximum positions of the operating pressures represents the fluid quantity stored.

ELM Series: How to order a Diaphragm accumulator

	Series	Volume	Max. working pressure (PS)	Regulation code	Form	Execution	Construction	Nitrogen gas Pre-charge
	ELM	0.75	350	/85	A	F	01125	Po=90b
ELM diaphragm accumulators.								
in Litres								
in Bar								
00 : According to the PED, article 3.3								
85 : SELO Approval only 0.32 to 1 L								
88 : SELO & CE approvals for volumes greater than 1 L								
A : internal threaded								
C : internal threaded external threaded								
F : Standard (nitrogen rechargeable)								
G : Request (Pre-charged with nitrogen in factory)								
011** : Carbon steel								
019** : Stainless steel								
***25 : NBR nitrile standard rubber								
***02 : ECO Hydrin rubber								
Other fluids and temperatures, contact Parker Olaer.								
in Bar at 20 ° C								

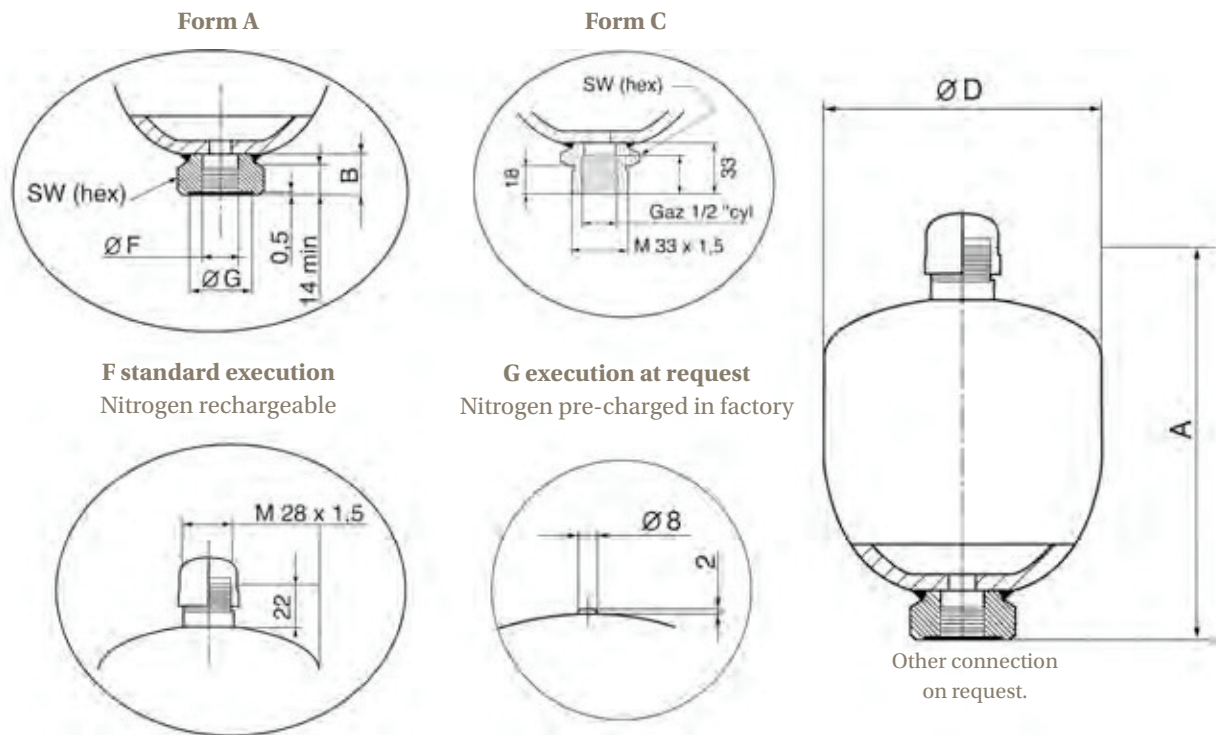

ELM Series 140 - 350 BAR, 0.075 to 1.4 Litres

Standard Version (Steel casing/mix NBR) for mineral oils temperature from - 20° up to 80°C

According to PED 97/23/EC, Fluid Group 2 and SELO

Part numbers, Accessories, Dimensions

Type Part number	Pre-charge	Clamps
	1 - 130 bar	Model (quantity) Part number
ELM 0.075-250/00/AF* 10849201125	751013	-
ELM 0.16-250/00/AF* 10849301125	751013	-
ELM 0.32-210/85/AF* 10986601125	751000	E95 (1) 20250803648
ELM 0.5-210/85/AF* 10849501125	751000	E106 (1) 20250903648
ELM 0.5-210/85/CF* 10849601125	751000	E106 (1) 20250903648
ELM 0.75-210/85/AF* 10849701125	751010	E114 (1) 20251003648
ELM 0.75-210/85/CF* 10849801125	751010	E114 (1) 20251003648
ELM 0.75-350/85/AF* 10931801125	751010	E136 (1) 20251103648
ELM 0.75-350/85/CF* 10931901125	751010	E136 (1) 20251303648
ELM 1 - 210/85/AF* 10984701125	751001	E136 (1) 20251103648
ELM 1 - 210/85/CF* 10984801125	751001	E136 (1) 20251103648
ELM 1.4 - 140/88/AF 10850201125	751014	E155 (1) 20251203648
ELM 1.4 - 140/88/CF 10850301125	751014	E155 (1) 20251203648
ELM 1.4 - 210/88/AF 10996501125	751014	E155 (1) 20251203648
ELM 1.4 - 210/88/CF 10996601125	751014	E155 (1) 20251203648

* According to the PED, article 3.3

Type	Effective Gas vol. Litres	Max. Working pressure (PS) bar	Execution form	Max. Pre-charge bar	Max compression in bar ratio P2/P0	Max Pressure amplitude P2/P1	Weight kg	Dimensions in mm					Oilport		Lock Nut type
								A max Height	B	SW	D	G	F	H	
ELM 0.075-250/00/AF*	0.075	250	AF	130	8	210	0.7	112	22	32	64	29	G½	-	-
ELM 0.16-250/00/AF*	0.16	250	AF	130	6	210	1	120	20	32	75	29	G½	-	-
ELM 0.32-210/85/AF*	0.32	210	AF	130	8	140	1.4	134	20	32	93	29	G½	-	-
ELM 0.5-210/85/AF*	0.50	210	AF	130	8	175	2	153	22	41	106	34	G½	-	-
ELM 0.5-210/85/CF*	0.50	210	CF	130	8	175	2	163	22	41	106	-	G½	M33x1.5	M33
ELM 0.75-210/85/AF*	0.75	210	AF	130	8	175	2.6	166	22	41	122	34	G½	-	-
ELM 0.75-210/85/CF*	0.75	210	CF	130	8	175	2.6	177	33	41	122	-	G½	M33x1.5	M33
ELM 0.75-350/85/AF*	0.75	350	AF	130	8	150	4	168	18	41	133	34	G½	-	-
ELM 0.75-350/85/CF*	0.75	350	CF	130	8	150	4	184	18	41	133	-	G½	M33x1.5	M33
ELM 1-210/85/AF*	1	210	AF	130	8	170	3.5	180	22	41	136	34	G½	-	-
ELM 1-210/85/CF*	1	210	CF	130	8	170	3.5	191	33	41	136	-	G½	M33x1.5	M33
ELM 1.4-140/88/AF	1.40	140	AF	130	8	120	4.1	191	22	41	148	34	G½	-	-
ELM 1.4-140/88/CF	1.40	140	CF	130	8	120	4.1	202	33	41	148	-	G½	M33x1.5	M33
ELM 1.4-210/88/AF	1.40	210	AF	130	8	120	4.2	191	22	41	148	34	G½	-	-
ELM 1.4-210/88/CF	1.40	210	CF	130	8	120	4.2	202	33	41	148	-	G½	M33x1.5	M33

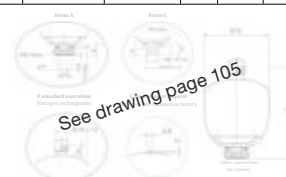

Above dimensions are in mm and are subject to manufacturing tolerances.

ELM Series 160 - 350 BAR, 0.75 to 3.5 Litres

Standard Version (Steel casing mix NBR) for mineral oils and for volume 1.4 L temperature from - 20° up to 80°C for volume ≥ 2 L temperature from - 10°C up to 80°C. According to PED 97/23/CE, Fluid Group 2 and SELO
Part numbers, Accessories, Dimensions

Type Part number	Pre-charge	Clamps
	1 to 109 bar	Model (quantity) Part number
ELM 1.4 - 250/88/AF 11013201125	751014	E155 (1) 20251203648
ELM 1.4 - 250/88/CF 11013301125	751014	E155 (1) 20251203648
ELM 1.4 - 350/88/AF 10932101125	751014	E155 (1) 20251203648
ELM 1.4 - 350/88/CF 10932201125	751014	E155 (1) 20251203648
ELM 2 - 100/88/AF 10850401125	751014	E155 (1) 20251203648
ELM 2 - 250/88/AF 11013401125	751014	E155 (1) 20251203648
ELM 2 - 350/88/AF 11006001125	751014	E155 (1) 20251203648
ELM 2 - 350/88/CF 11006101125	751014	E155 (1) 20251203648
ELM 2.8 - 250/88/AF 10887901125	751002	E168 (1) 20251303648
ELM 2.8 - 350/88/AF 10975801125	751002	E180 (1) 20243203625
ELM 2.8 - 350/88/CF 10975901125	751002	E180 (1) 20243203625
ELM 3.5 - 250/88/AF 10850501125	751012	E168 (1) 20251303648
ELM 3.5 - 350/88/AF 10984901125	751012	E180 (1) 20243203625
ELM 3.5 - 350/88/CF 10985001125	751012	E180 (1) 20243203625
ELM 0.75-160/88/CF** 10854901925	751010	E136 (1)**

** According to PED, article 3.3 and stainless steel construction

Type	Effective Gas vol. Litres	Max. Working pressure (PS) bar	Execution form	Max. Pre-charge bar	Max compression in bar ratio P2/P0	Max Pressure amplitude P2/P1	Weight kg	Dimensions in mm					Oilport		Lock Nut type
								A max Height	B	SW	D	G	F	H	
ELM 1.4-250/88/AF	1.40	250	AF	130	8	140	5.5	199	22	41	155	34	G½	-	-
ELM 1.4-250/88/CF	1.40	250	CF	130	8	140	5.5	209	33	41	155	-	G½	M33x1.5	M33
ELM 1.4-350/88/AF	1.40	350	AF	130	8	150	7	199	20	41	160	34	G½	-	-
ELM 1.4-350/88/CF	1.40	350	CF	130	8	150	7	220	20	41	160	-	G½	M33x1.5	M33
ELM 2-100/88/AF	2	100	AF	130	8	80	3.5	240	22	41	144	34	G½	-	-
ELM 2-250/88/AF	2	250	AF	130	8	140	9.5	251	22	41	155	33	G¾	-	-
ELM 2-350/88/AF	2	350	AF	130	8	200	9.5	219	22	55	156	34	G¾	-	-
ELM 2-350/88/CF	2	350	CF	130	8	200	9.5	240	22	55	156	-	G¾	M45x1.5	M45
ELM 2.8-250/88/AF	2.80	250	AF	130	6	140	10	268	21	41	174	34	G¾	-	-
ELM 2.8-350/88/AF	2.80	350	AF	130	6	200	14.3	264	21	55	180	34	G¾	-	-
ELM 2.8-350/88/CF	2.80	350	CF	130	6	200	14.3	285	21	55	180	-	G¾	M45x1.5	M45
ELM 3.5-250/88/AF	3.50	250	AF	130	4	140	11	307	21	41	174	33	G¾	-	-
ELM 3.5-350/88/AF	3.50	350	AF	130	4	200	16	304	21	55	180	34	G¾	-	-
ELM 3.5-350/88/CF	3.50	350	CF	130	4	200	16	325	21	55	180	-	G¾	M45x1.5	M45
ELM 0.75-160/88/CF**	0.75	160	CF	130	8	120	2.6	176	33	41	121	-	G½	-	-

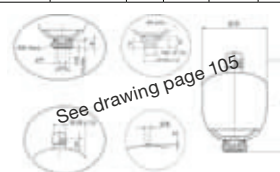

Above dimensions are in mm and are subject to manufacturing tolerances.

ELM Series 140 - 350 BAR, 0.075 to 3.5 Litres

ECO Version (Steel casing/mix ECO) for mineral oils temperature from - 35°C up to 80°C

According to PED 97/23/EC, Fluid Group 2 and SELO

Part numbers, Accessories, Dimensions

Type Part number	Pre-charge	Clamps
	1 - 109 bar	Model (quantity) Part number
ELM 0.075-250/00/AF* 10849201102	751013	-
ELM 0.16-250/00/AF* 10849301102	751013	-
ELM 0.32-210/85/AF* 10986601102	751000	E95 (1) 20250803648
ELM 0.5-210/85/AF* 10849501102	751000	E106 (1) 20250903648
ELM 0.5-210/85/CF* 10849601102	751000	E106 (1) 20250903648
ELM 0.75-210/85/AF* 10849701102	751010	E114 (1) 20251003648
ELM 0.75-210/85/CF* 10849801102	751010	E114 (1) 20251003648
ELM 0.75-350/85/AF* 10931801102	751010	E114 (1) 20251003648
ELM 0.75-350/85/CF* 10931901102	751010	E114 (1) 20251003648
ELM 1-210/85/AF* 10984701102	751001	E136 (1) 20251103648
ELM 1-210/85/CF* 10984801102	751001	E136 (1) 20251103648
ELM 1.4-140/88/AF 10850201102	751014	E155 (1) 20251203648
ELM 1.4-140/88/CF 10850301102	751014	E155 (1) 20251203648
ELM 1.4-210/88/AF 10996501102	751014	E155 (1) 20251203648
ELM 1.4-210/88/CF 10996601102	751014	E155 (1) 20251203648

* according to the PED, article 3.3

Type	Effective Gas vol. Litres	Max. Working pressure (PS) bar	Execution form	Max. Pre-charge bar	Max compression in bar ratio P2/P0	Max Pressure amplitude P2/P1	Weight kg	Dimensions in mm					Oilport		Lock Nut type
								A max Height	B	SW	D	G	F	H	
ELM 0.075-250/00/AF*	0.075	250	AF	130	8	210	0.7	112	22	32	64	29	G½	-	-
ELM 0.16-250/00/AF*	0.16	250	AF	130	6	210	1	120	20	32	75	29	G½	-	-
ELM 0.32-210/85/AF*	0.32	210	AF	130	8	140	1.4	134	20	32	93	29	G½	-	-
ELM 0.5-210/85/AF*	0.50	210	AF	130	8	175	2	153	22	41	106	34	G½	-	-
ELM 0.5-210/85/CF*	0.50	210	CF	130	8	175	2	163	22	41	106	-	G½	M33x1.5	M33
ELM 0.75-210/85/AF*	0.75	210	AF	130	8	175	2.6	166	22	41	122	34	G½	-	-
ELM 0.75-210/85/CF*	0.75	210	CF	130	8	175	2.6	177	33	41	122	-	G½	M33x1.5	M33
ELM 0.75-350/85/AF*	0.75	350	AF	130	8	150	4	168	18	41	133	34	G½	-	-
ELM 0.75-350/85/CF*	0.75	350	CF	130	8	150	4	184	18	41	133	-	G½	M33x1.5	M33
ELM 1-210/85/AF*	1	210	AF	130	8	170	3.5	180	22	41	136	34	G½	-	-
ELM 1-210/85/CF*	1	210	CF	130	8	170	3.5	191	33	41	136	-	G½	M33x1.5	M33
ELM 1.4-140/88/AF	1.40	140	AF	130	8	120	4.1	191	22	41	148	34	G½	-	-
ELM 1.4-140/88/CF	1.40	140	CF	130	8	120	4.1	202	33	41	148	-	G½	M33x1.5	M33
ELM 1.4-210/88/AF	1.40	210	AF	130	8	120	4.2	191	22	41	148	34	G½	-	-
ELM 1.4-210/88/CF	1.40	210	CF	130	8	120	4.2	202	33	41	148	-	G½	M33x1.5	M33

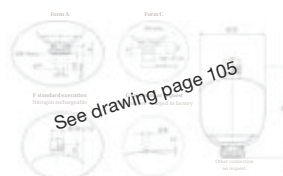

Above dimensions are in mm and are subject to manufacturing tolerances.

ELM Series 250 - 350 BAR, 1.4 to 3.5 Litres

ECO Version (Steel casing/mix ECO) for mineral oils temperature from - 35°C up to 80°C

According to PED 97/23/EC, Fluid Group 2 and SELO

Part numbers, Accessories, Dimensions

Type Part number	Pre-charge	Clamps
	1 to 109 bar	Model (quantity) Part number
ELM 1.4-250/88/AF 11013201102	751014	E155 (1) 20251203648
ELM 1.4-250/88/CF 11013301102	751014	E155 (1) 20251203648
ELM 1.4-350/88/AF 10932101102	751014	E155 (1) 20251203648
ELM 1.4-350/88/CF 10932201102	751014	E155 (1) 20251203648
ELM 2-100/88/AF 10850401102	751014	E155 (1) 20251203648
ELM 2-250/88/AF 11013401102	751014	E155 (1) 20251203648
ELM 2-350/88/AF 11006001102	751014	E155 (1) 20251203648
ELM 2-350/88/CF 11006101102	751014	E155 (1) 20251203648
ELM 2.8-250/88/AF 10887901102	751002	E168 (1) 20251303648
ELM 2.8-350/88/AF 10975801102	751002	E180 (1) 20243203625
ELM 2.8-350/88/CF 10975901102	751002	E180 (1) 20243203625
ELM 3.5-250/88/AF 10850501102	751012	E168 (1) 20251303648
ELM 3.5-350/88/AF 10984901102	751012	E180 (1) 20243203625
ELM 3.5-350/88/CF 10985001102	751012	E180 (1) 20243203625

Type	Effective Gas vol. Litres	Max. Working pressure (PS) bar	Execution form	Max. Pre-charge bar	Max compression in bar ratio P2/P0	Max Pressure amplitude P2/P1	Weight kg	Dimensions in mm					Oilport		Lock Nut type
								A max Height	B	SW	D	G	F	H	
ELM 1.4-250/88/AF	1.40	250	AF	130	8	140	5.5	199	22	41	155	34	G½	-	-
ELM 1.4-250/88/CF	1.40	250	CF	130	8	140	5.5	209	33	41	155	-	G½	M33x1.5	M33
ELM 1.4-350/88/AF	1.40	350	AF	130	8	150	7	199	20	41	160	34	G½	-	-
ELM 1.4-350/88/CF	1.40	350	CF	130	8	150	7	220	20	41	160	-	G½	M33x1.5	M33
ELM 2-100/88/AF	2	100	AF	130	8	80	3.5	240	22	41	144	34	G½	-	-
ELM 2-250/88/AF	2	250	AF	130	8	140	9.5	251	22	41	155	33	G¾	-	-
ELM 2-350/88/AF	2	350	AF	130	8	200	9.5	219	22	55	156	34	G¾	-	-
ELM 2-350/88/CF	2	350	CF	130	8	200	9.5	240	22	55	156	-	G¾	M45x1.5	M45
ELM 2.8-250/88/AF	2.80	250	AF	130	6	140	10	268	21	41	174	34	G¾	-	-
ELM 2.8-350/88/AF	2.80	350	AF	130	6	200	14.3	264	21	55	180	34	G¾	-	-
ELM 2.8-350/88/CF	2.80	350	CF	130	6	200	14.3	285	21	55	180	-	G¾	M45x1.5	M45
ELM 3.5-250/88/AF	3.50	250	AF	130	4	140	11	307	21	41	174	33	G¾	-	-
ELM 3.5-350/88/AF	3.50	350	AF	130	4	200	16	304	21	55	180	34	G¾	-	-
ELM 3.5-350/88/CF	3.50	350	CF	130	4	200	16	325	21	55	180	-	G¾	M45x1.5	M45



Above dimensions are in mm and are subject to manufacturing tolerances.

Clamps

Clamps : Steel with zinc plated protection, Rubber EPDM (Version 48), Rubber NBR Nitrile (Version 25)

Part numbers, Dimensions

Type	Design	RECOMMENDED Min to Max TIGHTENING ϕ mm
A56 20149203625	E	54 to 56
E95 20250803648	E	87 to 97
E106 20250903648	E	99 to 109
E114 20251003648	E	112 to 124
E136 20251103648	E	128 to 138
E155 20251203648	E	146 to 157
E160 20259003648	E	155 to 165
E168 20251303648	E	166 to 176
E180 20243203625	E	178 to 184
D215 20251403648	D	215 to 219
D226 20251503648	D	219 to 226
D368 20127403625	D	363 to 368

Type	Dimensions in mm												Recommended tightening torque N.m	Recommended max allowable weight if vertical equipment kg	Recommended max allowable weight if horizontal equipment kg
	A	B	C		D	E	F	G	H	I	J	K			
			Min	Max											
A56	92	102	36	36	3	37	M10x80	3	31	14	9	134	7	10	30
E95	88	140	61.5	66.5	1.5	28	M8x75	3	40	35	9	155	7	30	90
E106	88	140	68	73	1.5	28	M8x75	3	40	35	9	155	7	30	90
E114	88	140	73	78	1.5	28	M8x75	3	40	35	9	155	7	30	90
E136	88	140	80	85	1.5	28	M8x75	3	40	35	9	155	7	30	90
E155	137	189	81	86.5	1.7	30	M10x80	3	45	35	9	210	10.5	60	60
E160	137	189	86.88	91.88	1.7	32	M10x80	3	45	35	9	210	10.5	60	60
E168	137	189	92	96	1.7	30	M10x80	3	45	35	9	210	10.5	60	60
E180	137	189	97	100	2	35	M10x80	4	65	35	9	210	10.5	60	60
D215	210	222	123	125	3	36	M12x70	3	40	21	15	266	9	65	110
D226	210	222	119	122.5	3	35	M12x80	3	40	21	15	270	11	75	150
D368	334	346	198.5	201	3	36	M12x75	3	50	21	15	420	11	50	80

Shape D

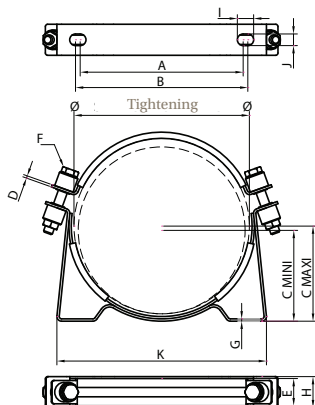

Shape E

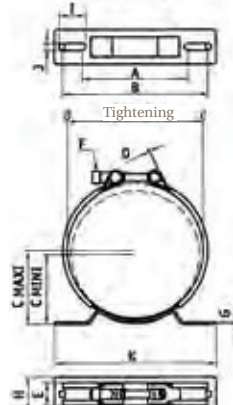

Clamps

Clamps : **Stainless Steel** with Nitrile rubber mouldings.

Part numbers, Dimensions

Part Number	Diagram	Accumulator Capacity (Litres)	
10957	C	0.6	
10981	C	1 - 3	
10982	B	4 - 9	
10983	B	10 - 54	
11060	A	12 - 54 HP200	

Type	Dimensions in mm										Mounting Bolts	Mass kg
	A	B	C	D	E	F	G (ref)	H	I			
10957	143	127	90	96	30	-	60	13	9	M8 x 30	0.59	
10981	137	144	100	111 - 116	30	-	73	13	9	M8 x 80	0.75	
10982	190	186	146	170	30	244	100	13	9	M8 x 80	1.25	
10983	250	267	211	218 - 228	40	306	129	21	15	M12 x 80	1.50	
11060	270	280	220	256 - 261	40	345	140	10.5	10.5	M10 x 50	2	

Diagram A

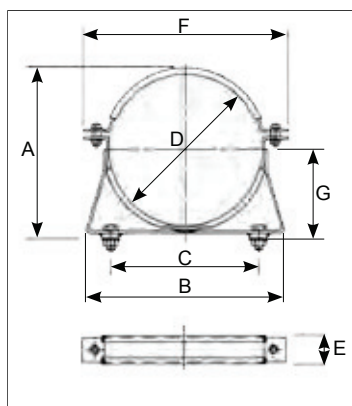

Diagram B

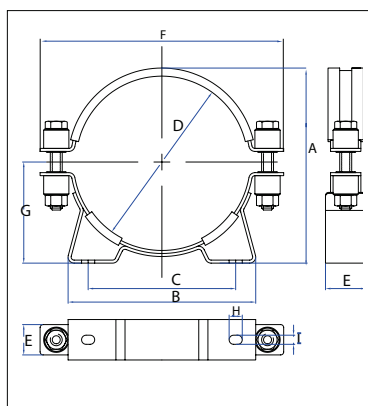
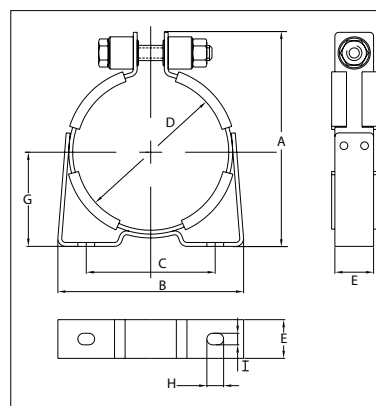

Diagram C



Support Brackets

Type	Models
Part number	
CE89 20151903620	Accumulators 1 to 5 Litres
CE108 20118703620	EHV 4 & 6 & 10 Litres
CE159A 20109003620	Accumulators 10 to 50 Litres < 550 Bar
CE300 20150800100	Accumulators 100-200 Litres

Mounting Frames

Type	For Models EHV
Part number	
EF1 20217500125	EHV 4 & 6 & 10 Litres
EF2 20217600125	EHV 10 & 12 & 20 & 24.5 Litres
EF3 20217700125	EHV 32 & 50 Litres

Accessories

Type	Design	Dimensions in mm													Weight kg
		A	B	C	H	I	J	K	L	M	N	R	S		
CE89	A	89	101	125	73	140	75	13	25	60	75	130	-	0.8	
CE108	A	108	120	150	92	175	95	17	25	80	160	210	-	1.5	
CE159A	B	159	170	200	123	235	115	17	25	100	200	260	40	2.5	
CE300	B	30	-	-	200	380	300	20	50	300	375	475	200	30	

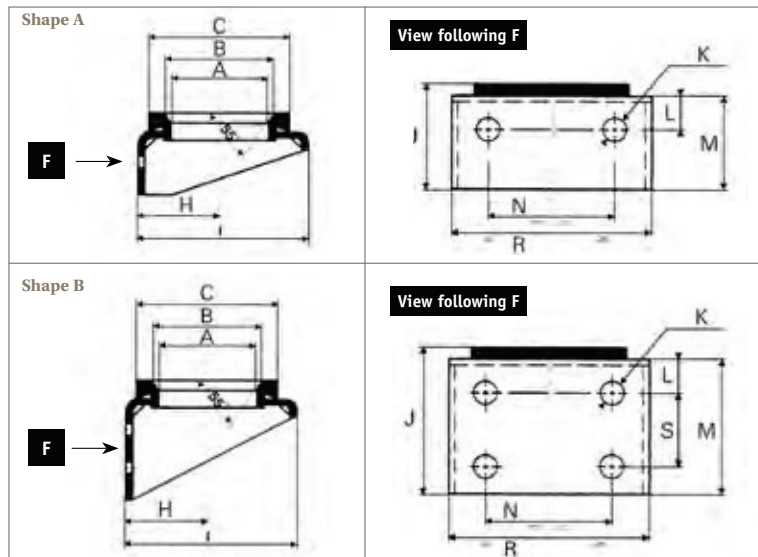

Type	Dimensions in mm									
	A	B	C	D	E	F	G	H	J	
EF1	670	570	225	92	96	340	370	270	50	
EF2	670	570	285	123	115	340	370	270	50	
EF3	1405	1300	285	123	115	340	370	270	55	

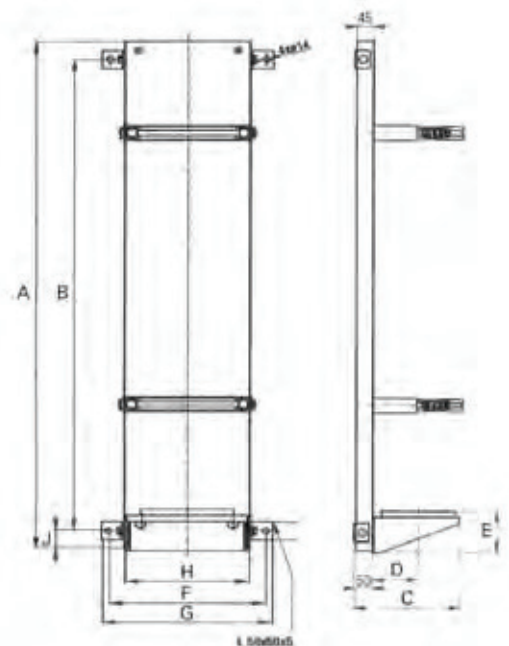

Accessories

Charging Set VGU

The charging set VGU is an indispensable instrument for the verification, pressurization and nitrogen bleeding of most of the hydraulic accumulators available on the market. The standard set is delivered in a storage case containing the following:

- VGU universal tester and pressurizer (end M28 x 1.50).
- Pressure gauge kit from 0 to 25 bar.
- Pressure gauge kit from 0 to 250 bar.
- Connection adapters for inflation valves (7/8" - 5/8" - 8V1 - M28 x 1.50).
- High pressure hose, 2.5 m long, for connecting to a nitrogen source.
- Hexagon socket screw key 6mm.
- Jackets of replacement joints.
- Operating instruction in French, English, German.



Note: On request, the following options are available:

- Pressure gauge kits with different scale divisions: 63mm with glycerol bath back end G1/4" cyl. equipped with direct gear for Minimes® connection. Scale divisions 0-10, 0-60, 0-100, 0-400, with accuracy class 1.6%.
- High pressure hose of different length with adapters for nitrogen bottles from various countries (specify country), at each end with a female swivel coupling G1/4" for connecting to the inflation port.

Maximum working pressure: limited by the maximum operating pressure of the installed hydraulic system, pressure limited to **400 bar** in any case.

How to order a VGU Charging Set

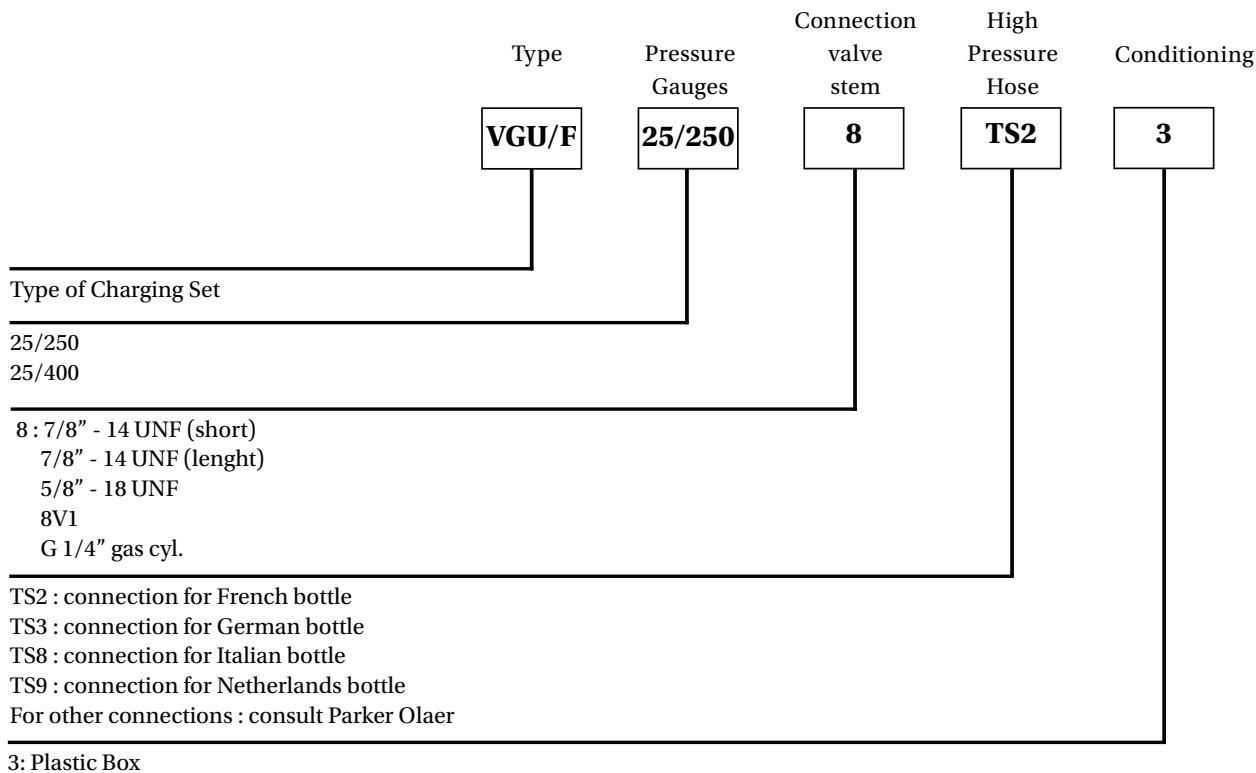

Accessories

Type	Spare Parts	
	High Pressure Hose	Spare Part Kits
	Type	Type
Part number	Part number	Part number
VGU/F.25/250.8.TS2.3	TS2 (France)	
20214122823	20214800000	10774100023
VGU/F.25/250.8.TS3.3	TS3 (Germany)	
20214122833	20228000000	10774100023
VGU/F.25/250.8.TS8.3	TS8 (Italy)	
20214122883	20217200000	10774100023
VGU/F.25/250.8.TS9.3	TS9 (Netherlands)	
20214122893	20227300000	10774100023
VGU/F.25/400.8.TS2.3	TS2 (France)	
20214139823	20214800000	10774100023
VGU/F.25/400.8.TS3.3	TS3 (Germany)	
20214139833	20228000000	10774100023
VGU/F.25/400.8.TS8.3	TS8 (Italy)	
20214139883	20217200000	10774100023
VGU/F.25/400.8.TS9.3	TS9 (Netherlands)	
20214139893	20227300000	10774100023

Spare Parts Gauge Kit VGU

Type
Part number
0 to 25 bar
00090300000
0 to 250 bar
00090500000
0 to 400 bar
00090600000

Spare Parts Adaptors VGU

Type
Part number
Adaptor 7/8" - 14 UNF
20212700223
Adaptor 5/8" - 18 UNF
20213000223
Coupling 8 V1
20214000200
Adaptor 7/8" - 14 UNF
20213500223
Adaptor 1/4" cyl
20221100220

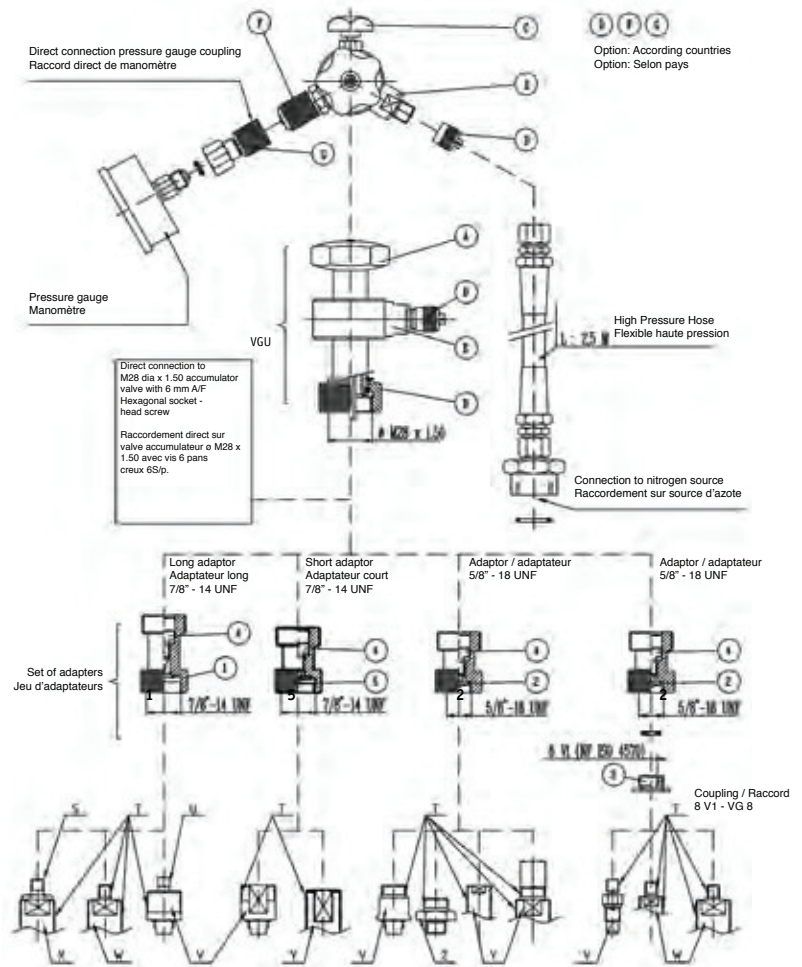

Safety Blocks

Parker Olaer has developed a complete range of decompressing and isolating blocks (sizes 10 to 50) to answer all standard and special applications.

These blocks are in conformity with the European Directive on the equipment under pressure (97/23), these appliances have been designed to group together in a single compact unit all the components necessary for the correct operation of a hydraulic system equipped with hydropneumatic accumulators.

The basic block consists of :

- Isolating valve to isolate the accumulator from the circuit for all the blocks except from model DI 10 where it also ensures the decompression function.
- A drain valve for decompressing the accumulator for all models (except DI 10)
- A pressure relief valve EC with poppet calibrated generally to the maximum service pressure of the accumulator (under no circumstances must this appliance be used to protect the hydraulic pump)
- Pressure tapping port (M)

In the E version, the basic block, to decompress the accumulator, can be equipped with an electro-valve :

- 2 ways 2 positions (DI 10/DI 20/DI 32) cartridge type.
- 3 ways 2 positions (DI 16/DI 24) with impact of connection according to DIN 24340 Form A, ISO 4401 and CETOP RP 121 H.



DI Series: How to order a Safety Block

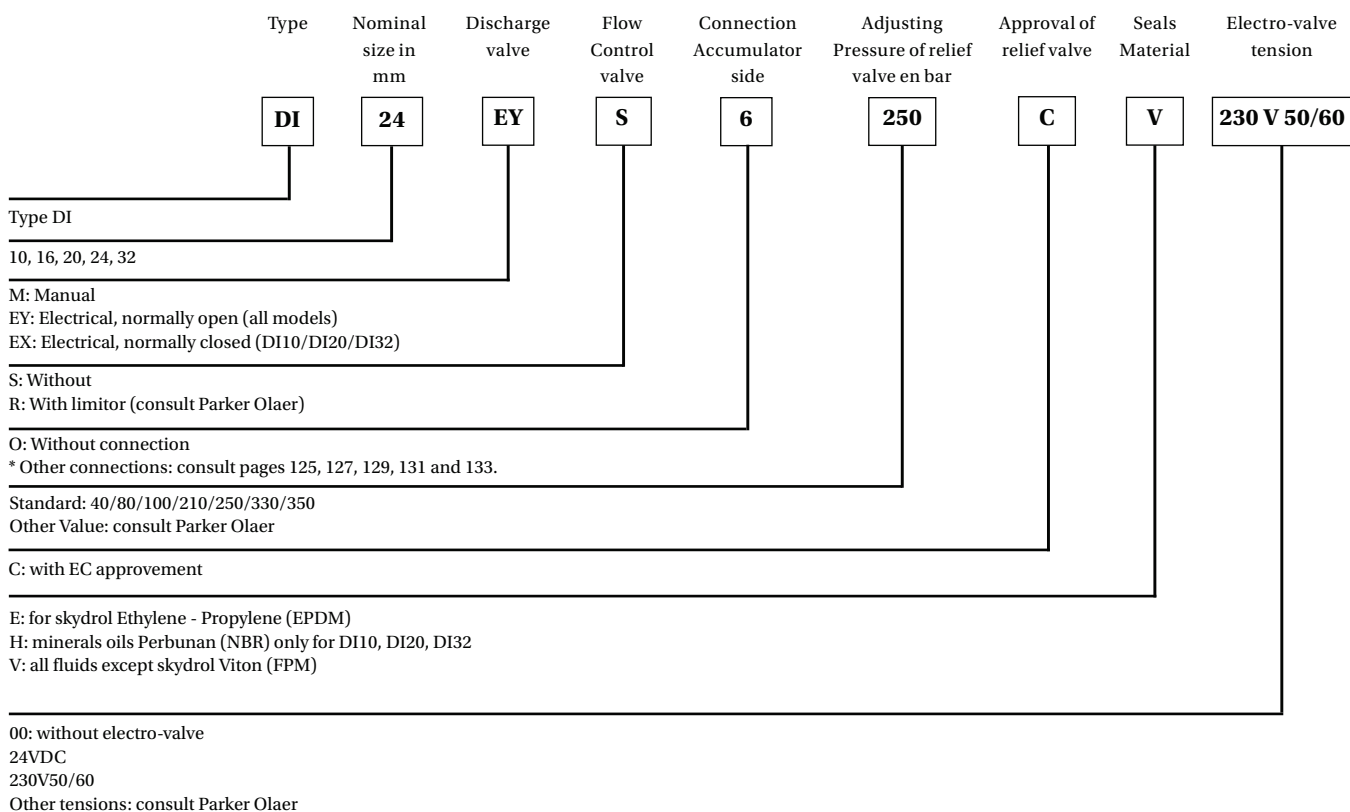

Connection accumulator side for block D10 - DI16 - DI20 - DI24 - DI32

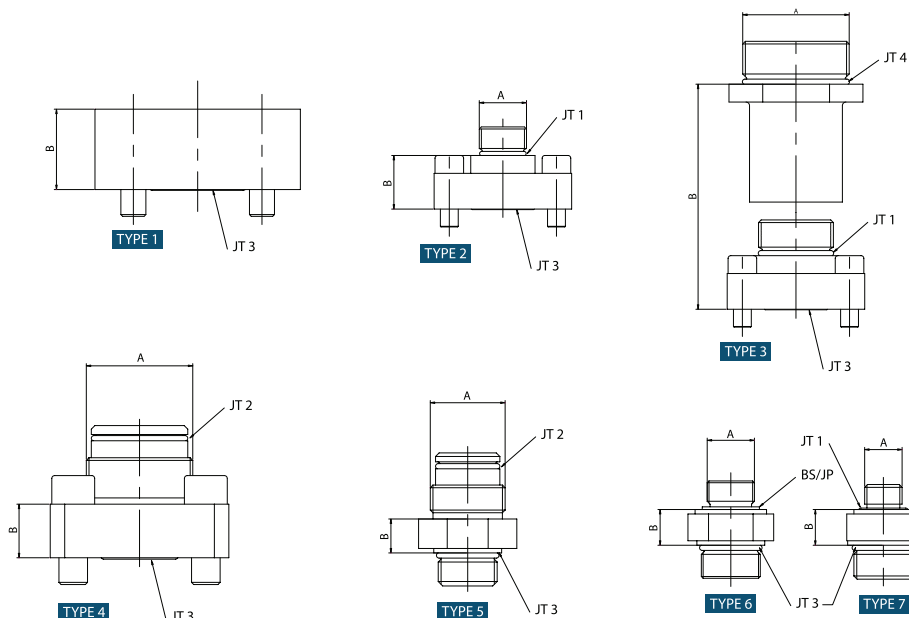

Models	Application	A	B	Sealing						Type	Codif
				JT1 (angle)	JT2 (piston)	JT3	JT4	BS	JP		
DI10 MS/ES	ELM 0.075-250/ 0.16-250/ 0.32-210	G 1/2"	20	-	-	29 x 3	-	28.7 x 21.5 x 2.5	-	6	5
	ELM	G 1/2"	20	22 x 3	-	29 x 3	-	-	-	7	4
	ELM	G 3/4"	20	-	-	29 x 3	-	-	32 x 27 x 1.5	6	6
DI20 MS/ES	EHV 0.5 to 1.6 L	G 3/4"	18	-	17 x 3	29 x 3	-	-	-	5	2
	EHV 2.5 to 10 L (long)	G1 1/4"	19	-	30 x 3	29 x 3	-	-	-	5	1
	EHV 10 to 50 L	G2"	36.5	-	48 x 3	29 x 3	-	-	-	5	3
DI16 MS/ES	EHV 0.5 to 1.6 L	G 3/4"	30	21.3 x 2.5	-	32 x 2	-	-	-	2	2
	EHV 0.5 to 1.6 L	G 3/4"	30	-	16.9 x 2.7	32 x 2	-	-	-	4	F
	EHV 2.5 tot 10 L (long)	G1 1/4"	30	36.2 x 3	-	32 x 2	-	-	-	2	1
	EHV 2.5 tot 10 L (long)	G1 1/4"	30	-	30 x 3	32 x 2	-	-	-	4	D
	EHV 10 to 50 L	G2"	96	36.2 x 3	-	32 x 2	54 x 3	-	-	3	3
	EHV 10 to 50 L	G2"	116	-	48 x 3	32 x 2	-	-	-	4	7
	EHVF 10 to 50 L	1 1/2"-6000	33	-	-	32 x 2	-	-	-	1	J
	EHVF 2.5 to 10 L (long)	1 1/4"-3000	33	-	-	32 x 2	-	-	-	1	K
	EHVF 2.5 to 10 L (long)	1"-6000	33	-	-	32 x 2	-	-	-	1	K
DI24 MS/ES	EHV 0.5 to 1.6 L	G 3/4"	35	21.3 x 2.4	-	48 x 3	-	-	-	2	2
	EHV 2.5 to 10 L (long)	G1 1/4"	35	36.2 x 3	-	48 x 3	-	-	-	2	1
	EHV 2.5 to 10 L (long)	G1 1/4"	35	-	30 x 3	48 x 3	-	-	-	4	F
	EHV 10 to 50 L	G2"	35	54 x 3	-	48 x 3	-	-	-	2	3
	EHV 10 to 50 L	G2"	35	-	48 x 3	48 x 3	-	-	-	4	D
	EBV 100 to 200 L + Piston Accumulator	G2"	80	54 x 3	-	48 x 3	54 x 3	-	-	3	7
	EHVF 10 to 50 L	2"-3000	45	-	-	48 x 3	-	-	-	1	J
	EHVF 10 to 50 L	1 1/2"-6000	45	-	-	48 x 3	-	-	-	1	J
	EHVF 2.5 to 10 L (long)	1 1/4"-3000	45	-	-	48 x 3	-	-	-	1	K
	EHVF 2.5 to 10 L (long)	1"-6000	45	-	-	48 x 3	-	-	-	1	K
	DI32 MS/ES	EHV 0.5 to 1.6 L	G 3/4"	30	-	17 x 3	37.2 x 3	-	-	-	4
EHV 2.5 to 10 L		G1 1/4"	30	-	30 x 3	37.2 x 3	-	-	-	4	1
EHV 10 to 50 L		G2"	30	-	48 x 3	37.2 x 3	-	-	-	4	3

Above dimensions are in mm and are subject to manufacturing tolerances.

Safety Block DI 10

TECHNICAL DATA DI 10

- **Size:** Nominal diameter : 10 mm
- **Maxi working pressure:** Manual version : 400 bar
Electrical version : 350 bar
- **Weight without connector:** Manual version : 3,5 kg
Electrical version : 4 kg
- **Materials:** Carbon steel
According with the fluids of group 2 (PED)
- **Temperature:** Manual version : - 10°C à + 70°C
Electrical version : - 10°C à + 60°C (ambient temperature)
- **Electrical data:** DC : 24 V
AC : 230 V-50/60 Hz
Standard protection : IP 65
Standard connector : DIN 43650
- **Connection accumulator side:** See page 123
- **Pressure / return connector of circuit:** See hydraulic drawing
- **Pressure relief valve EC (nominal dia):** 10 mm
- **Flow:** Consult the diagram

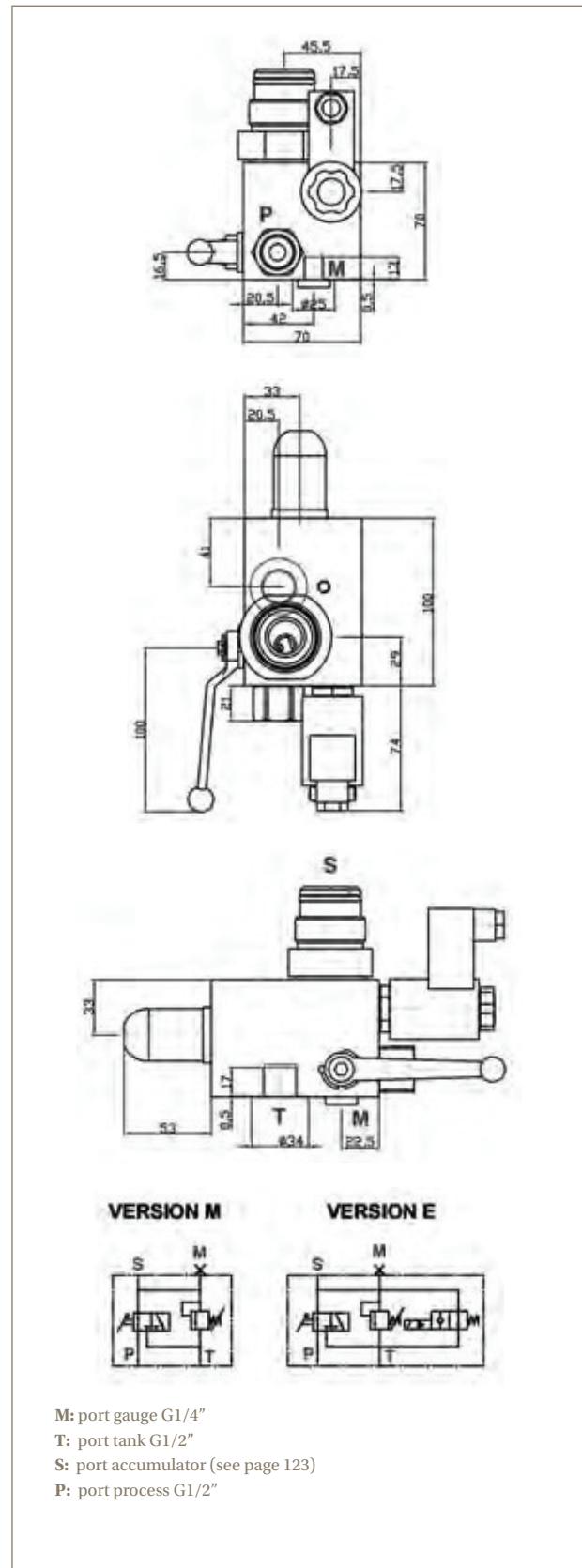
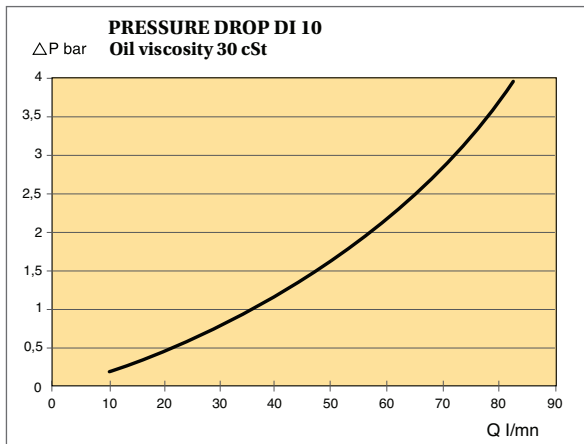

Above dimensions are in mm and are subject to manufacturing tolerances.

Safety Block DI 10 Manual Version

Standard version (Carbon steel, rings NBR) temperature -10°C up to 70°C Maximum working pressure : 400 Bar
According to PED 97/23/EC

Part numbers

Connecting to accumulator	Type	Part number
EHV 0.5 to 1.6 L G3/4	DI10MS/2/350CH	35172112Y01
EHV 10 to 50 L G2"	DI10MS/3/330CH	35172113J01
ELM G1/2"	DI10MS/4/100CH	35172114D01
ELM G1/2"	DI10MS/4/140CH	35172114Q01
ELM G1/2"	DI10MS/4/210CH	35172114G01
ELM G1/2"	DI10MS/4/250CH	35172114H01
ELM G1/2"	DI10MS/4/330CH	35172114J01
ELM G1/2"	DI10MS/4/350CH	35172114Y01
ELM 0,32-210 G1/2"	DI10MS/5/210CH	35172115G01
ELM 0,075-250/0,16-250 G1/2"	DI10MS/5/250CH	35172115H01
ELM G3/4"	DI10MS/6/100CH	35172116D01
ELM G3/4"	DI10MS/6/140CH	35172116Q01
ELM G3/4"	DI10MS/6/210CH	35172116G01
ELM G3/4"	DI10MS/6/250CH	35172116H01
ELM G3/4"	DI10MS/6/330CH	35172116J01
ELM G3/4"	DI10MS/6/350CH	35172116Y01

Safety Block DI 10 Electrical Version

Standard version (Carbon steel, rings NBR) temperature -10°C up to 60°C Maximum working pressure : 350 Bar
According to PED 97/23/EC

Part numbers

Connecting to accumulator	With Electro-valve tension 24VDC		With Electro-valve tension 230V50/60	
	Type	Part number	Type	Part number
EHV 2.5 to 10 L (long) G1 1/4*	DI10EYS/1/350CH24VCC	35172131Y21	DI10EYS/1/350CH230V50/60	35172131Y61
EHV 0.5 to 1.6 L G3/4*	DI10EYS/2/350CH24VCC	35172132Y21	DI10EYS/2/350CH230V50/60	35172132Y61
ELM G1/2"	DI10EYS/4/100CH24VCC	35172134D21	DI10EYS/4/100CH230V50/60	35172134D61
ELM G1/2"	DI10EYS/4/140CH24VCC	35172134Q21	DI10EYS/4/140CH230V50/60	35172134Q61
ELM G1/2"	DI10EYS/4/210CH24VCC	35172134G21	DI10EYS/4/210CH230V50/60	35172134G61
ELM G1/2"	DI10EYS/4/250CH24VCC	35172134H21	DI10EYS/4/250CH230V50/60	35172134H61
ELM G1/2"	DI10EYS/4/330CH24VCC	35172134J21	DI10EYS/4/330CH230V50/60	35172134J61
ELM G1/2"	DI10EYS/4/350CH24VCC	35172134Y21	DI10EYS/4/350CH230V50/60	35172134Y61
ELM 0.32 to 210 G1/2"	DI10EYS/5/210CH24VCC	35172135G21	DI10EYS/5/210CH230V50/60	35172135G61
ELM 0.075 to 250/0.16 to 250 G1/2"	DI10EYS/5/250CH24VCC	35172135H21	DI10EYS/5/250CH230V50/60	35172135H61
ELM G3/4"	DI10EYS/6/100CH24VCC	35172136D21	DI10EYS/6/100CH230V50/60	35172136D61
ELM G3/4"	DI10EYS/6/140CH24VCC	35172136Q21	DI10EYS/6/140CH230V50/60	35172136Q61
ELM G3/4"	DI10EYS/6/210CH24VCC	35172136G21	DI10EYS/6/210CH230V50/60	35172136G61
ELM G3/4"	DI10EYS/6/250CH24VCC	35172136H21	DI10EYS/6/250CH230V50/60	35172136H61
ELM G3/4"	DI10EYS/6/330CH24VCC	35172136J21	DI10EYS/6/330CH230V50/60	35172136J61
ELM G3/4"	DI10EYS/6/350CH24VCC	35172136Y21	DI10EYS/6/350CH230V50/60	35172136Y61

Options or Accessories

Type	Characteristics	Part number
RELIEF VALVE CE	100 BAR	35045931002
RELIEF VALVE CE	140 BAR	35045931402
RELIEF VALVE CE	210 BAR	35045932102
RELIEF VALVE CE	250 BAR	35045932502
RELIEF VALVE CE	330 BAR	35045933302
RELIEF VALVE CE	350 BAR	35045933502



Safety Block DI 16

TECHNICAL DATA DI 16

- **Size:** Nominal diameter : 16 mm
- **Maxi working pressure:** Manual version : 350 bar
Electrical version : 350 bar
- **Weight without connector:** Manual version : 4,3 kg
Electrical version : 5,8 kg
- **Materials:** Carbon steel
According with the fluids of group 2 (PED)
- **Temperature:** Manual version : - 15°C à + 70°C
Electrical version : - 15°C à + 50°C (ambient temperature)
- **Electrical data:** DC : 24 V
AC : 230 V-50/60 Hz
Standard protection : IP 65
Standard connector : DIN 43650
- Power consumption : 30 W
- **Connection accumulator side:** See page 123
- **Pressure / return connector of circuit:** See hydraulic drawing
- **Pressure relief valve EC (nominal dia):** 6 mm
- **Flow:** Consult the diagram

Possibility of assembly of a flow control valve on the block consult us.

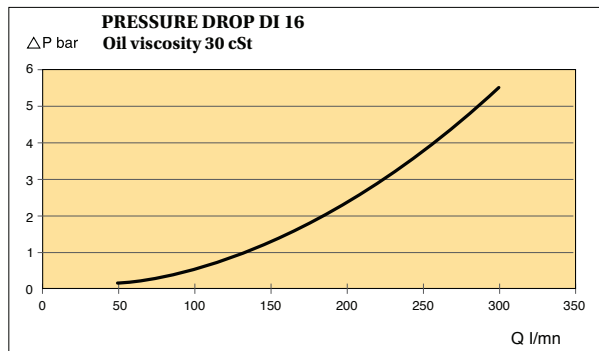

Minimes screw coupling
TYPE 1620

Positioning Cetop size 3
for clack electro-valve

VERSION E
View according to F

4 holes M5 - Depth of tapped 12 useful
Front hole depth : 16 on point

VERSION M **VERSION E**

M: screw coupling G 1/4" delivered with Minimes 1620
T: port tank G1/4" flattened dept 1 for bonded seal
A: port accumulator (see page 123)
P: port process G3/4" flattened depth 1.5 for bonded seal

Above dimensions are in mm and are subject to manufacturing tolerances.

Accessories

Safety Block DI 16 Manual Version

Standard version (Carbon steel, rings FKM) temperature -15°C up to 70°C Maximum working pressure : 350 Bar
According to PED 97/23/EC

Part numbers

Connecting to accumulator	Type	Part number
EHV 0,5 up to 1,6 L G3/4"	DI16MS/2/210 CV	35128812G02
EHV 0,5 up to 1,6 L G3/4"	DI16MS/2/250 CV	35128812H02
EHV 0,5 up to 1,6 L G3/4"	DI16MS/2/330 CV	35128812J02
EHV 0,5 up to 1,6 L G3/4"	DI16MS/2/350 CV	35128812Y02
EHV 2,5 up to 10 L G1"1/4	DI16MS/1/210 CV	35128811G02
EHV 2,5 up to 10 L G1"1/4	DI16MS/1/250 CV	35128811H02
EHV 2,5 up to 10 L G1"1/4	DI16MS/1/330 CV	35128811J02
EHV 2,5 up to 10 L G1"1/4	DI16MS/1/350 CV	35128811Y02
EHV 10 up to 50 L G2"	DI16MS/3/210 CV	35128813G02
EHV 10 up to 50 L G2"	DI16MS/3/250 CV	35128813H02
EHV 10 up to 50 L G2"	DI16MS/3/330 CV	35128813J02
EHV 10 up to 50 L G2"	DI16MS/3/350 CV	35128813Y02

Safety Block DI 16 Electrical Version

Standard version (Carbon steel, rings FKM) temperature -15°C up to 50°C Maximum working pressure : 350 Bar
According to PED 97/23/EC

Part numbers

Connecting to accumulator	with connection for adding Electrovalve 24 VDC	
	Type	Part number
EHV 0,5 up to 1,6 L G3/4"	DI16EYS/2/210 CV	35128832G02
EHV 0,5 up to 1,6 L G3/4"	DI16EYS/2/250 CV	35128832H02
EHV 0,5 up to 1,6 L G3/4"	DI16EYS/2/330 CV	35128832J02
EHV 0,5 up to 1,6 L G3/4"	DI16EYS/2/350 CV	35128832Y02
EHV 2,5 up to 10 L G1"1/4	DI16EYS/1/210 CV	35128831G02
EHV 2,5 up to 10 L G1"1/4	DI16EYS/1/250 CV	35128831H02
EHV 2,5 up to 10 L G1"1/4	DI16EYS/1/330 CV	35128831J02
EHV 2,5 up to 10 L G1"1/4	DI16EYS/1/350 CV	35128831Y02
EHV 10 up to 50 L G2"	DI16EYS/3/210 CV	35128833G02
EHV 10 up to 50 L G2"	DI16EYS/3/250 CV	35128833H02
EHV 10 up to 50 L G2"	DI16EYS/3/330 CV	35128833J02
EHV 10 up to 50 L G2"	DI16EYS/3/350 CV	35128833Y02

Options or Accessories

Type	Electro valve tension	Part number
ELECTRO-VALVE T3	24 VCC	35157700281
ELECTRO-VALVE T3	110/120VA 50/60 Hz	35157800281
ELECTRO-VALVE T3	220/230VA 50/60 Hz	35157900281
REGULATION BLOCK	R16	35141800281
FLANGE M 3/4" GAS CYL Connection Accumulator Side		35054100281
FLANGE M 1"1/4 GAS CYL Connection Accumulator Side		35054200281
FLANGE M 2" GAS CYL Connection Accumulator Side		35103500281
RELIEF VALVE CE	210	35045732102
RELIEF VALVE CE	250	35045732502
RELIEF VALVE CE	330	35045733302
RELIEF VALVE CE	350	35045733502



Safety Block DI 20

TECHNICAL DATA DI 20

- **Size:** Nominal diameter : 20 mm
- **Maxi working pressure:** Manual version : 400 bar
Electrical version : 350 bar
- **Weight without connector:** Manual version : 6,4 kg
Electrical version : 6,9 kg
- **Materials:** Carbon steel
According with the fluids of group 2 (PED)
- **Temperature:** Manual version : - 15°C à + 70°C
Electrical version : - 15°C à + 60°C (ambient temperature)
- **Electrical data:** DC : 24 V
AC : 230 V-50/60 Hz
Standard protection : IP 65
Standard connector : DIN 43650
- **Connection accumulator side:** See page 123
- **Pressure / return connector of circuit:** See hydraulic drawing
- **Pressure relief valve EC (nominal dia):** 10 mm
- **Flow:** Consult the diagram

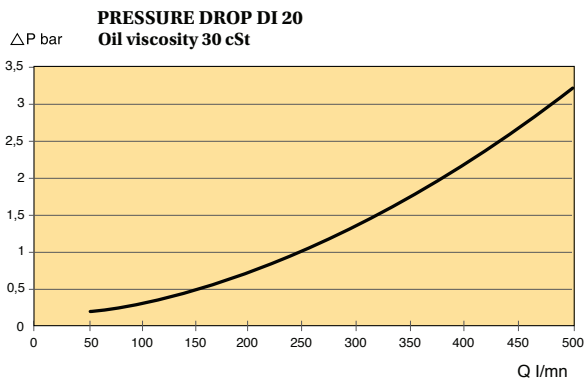
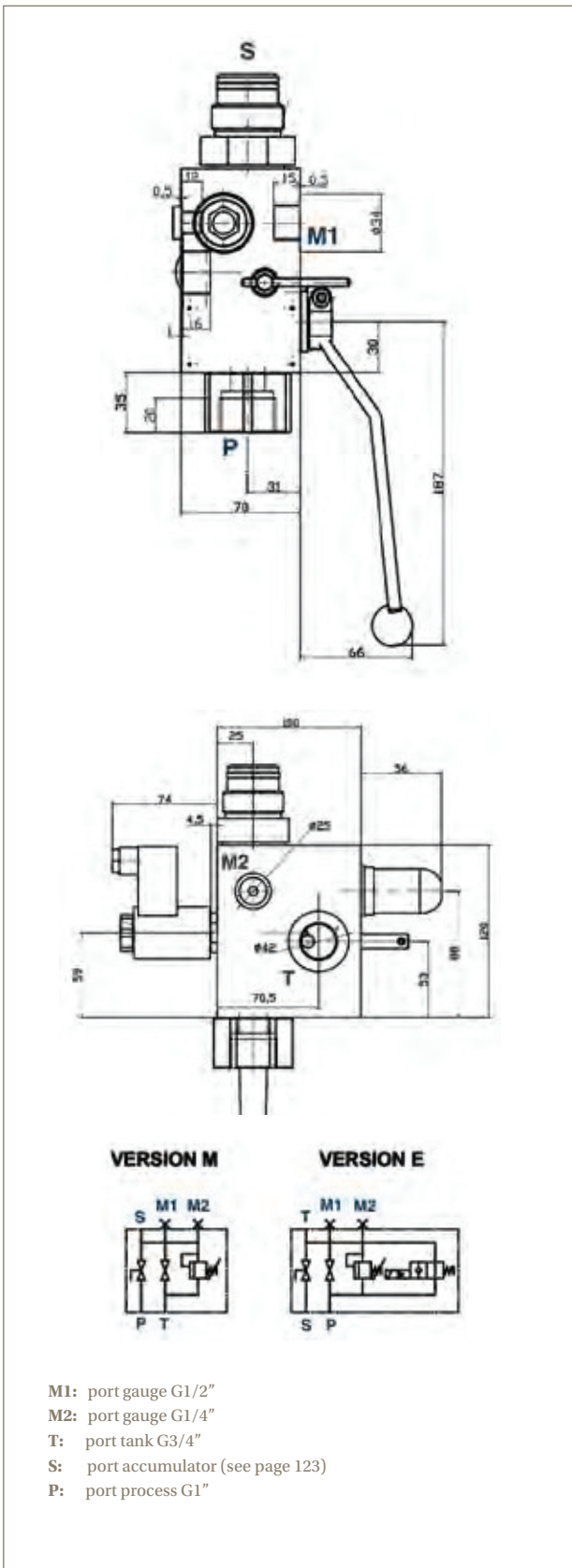

Above dimensions are in mm and are subject to manufacturing tolerances.

Accessories

Safety Block DI 20 Manual Version

Standard version (Carbon steel, rings NBR) temperature -10°C up to 70°C Maximum working pressure : 400 Bar
According to PED 97/23/EC

Part numbers

Connecting to accumulator	Type	Part number
EHV 2,5 up to 10 L G1"1/4	DI20MS/1/350CH	35172211Y01
EHV 10 up to 50 L G2"	DI20MS/3/330CH	35172213J01

Safety Block DI 20 Electrical Version

Standard version (Carbon steel, rings NBR) temperature -10°C up to 60°C Maximum working pressure : 350 Bar
According to PED 97/23/EC

Part numbers

Connecting to accumulator	Type	Part number	With Electro-valve tension 230V5/60	
			Type	Part number
EHV 10 up to 50 L G2"	DI20EYS/3/210CH24VCC	35172233G21	DI20EYS/3/210CH230V50/60	35172233G61
EHV 10 up to 50 L G2"	DI20EYS/3/330CH24VCC	35172233J21	DI20EYS/3/330CH230V50/60	35172233J61
EHV 2.5 up to 10 L G1 1/4"	DI20EYS/1/330CH24VCC	35172231J21	DI20EYS/3/350CH230V50/60	35172233Y61

Options or Accessories

Type	Characteristics	Part number
RELIEF VALVE CE	210 BAR	35045932102
RELIEF VALVE CE	250 BAR	35045932502
RELIEF VALVE CE	330 BAR	35045933302
RELIEF VALVE CE	350 BAR	35045933502



Safety Block DI 24

TECHNICAL DATA DI 24

- **Size:** Nominal diameter : 24 mm
- **Maxi working pressure:** Manual version : 350 bar
Electrical version : 350 bar
- **Weight without connector:** Manual version : 9,5 kg
Electrical version : 11 kg
- **Materials:** Carbon steel
- **Temperature:** Manual version : - 15°C à + 70°C
Electrical version : - 15°C à + 50°C (ambient temperature)
- **Electrical data:** DC : 24 V
AC : 230 V-50/60 Hz
Standard protection : IP 65
Standard connector : DIN 43650
- Power consumption : 30 W
- **Connection accumulator side:** See page 123
- **Pressure / return connector of circuit:** See hydraulic drawing
- **Pressure relief valve EC (nominal dia):** 10 mm
- **Flow:** Consult the diagram

Possibility of assembly of a flow control valve on the block consult us.

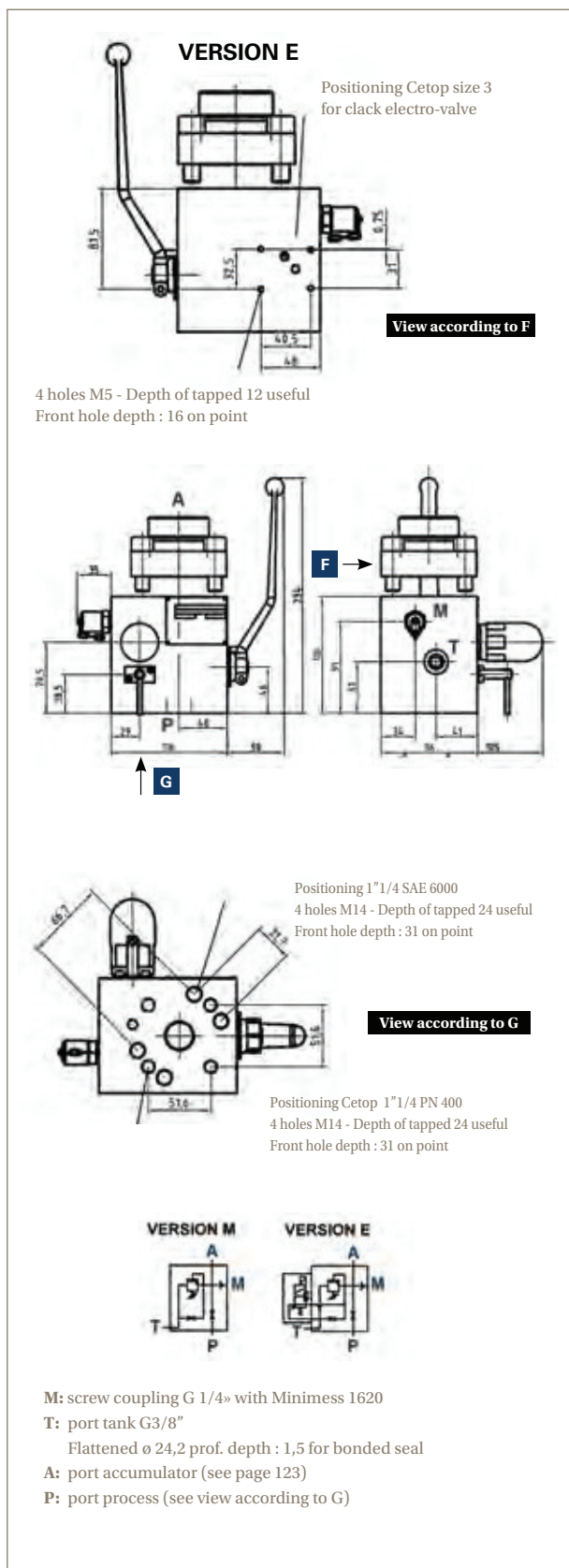
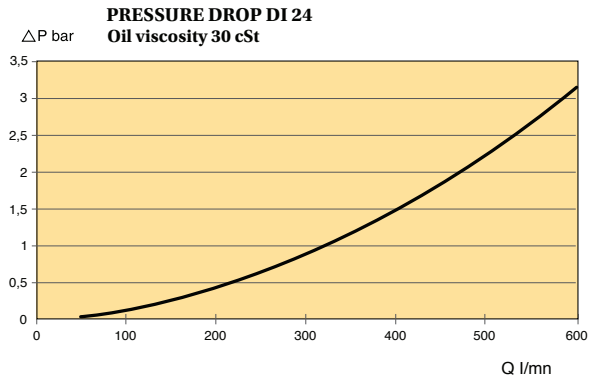

Above dimensions are in mm and are subject to manufacturing tolerances.

Safety Block DI 24 Manual Version

Standard version (Carbon steel, rings FKM) temperature -15°C up to 70°C Maximum working pressure : 350 Bar
According to PED 97/23/EC

Part numbers

Connecting to accumulator	Type	Part number
EHV 2,5 up to 10 L G1"1/4	DI24MS/1/330CV	35129011J02
EHV 2,5 up to 10 L G1"1/4	DI24MS/1/350CV	35129011Y02
EHV 10 up to 50 L G2"	DI24MS/3/210CV	35129013G02
EHV 10 up to 50 L G2"	DI24MS/3/250CV *	35129013H02
EHV 10 up to 50 L G2"	DI24MS/3/330CV *	35129013J02
ACCU PISTON 10 up to 50 L G2"&EBV 100 and 200 L	Consult Division	

* without electro-valve

Safety Block DI 24 Electrical Version

Standard version (Carbon steel, rings FKM) temperature -15°C up to 50°C Maximum working pressure : 350 Bar
According to PED 97/23/EC

Part numbers

Connecting to accumulator	with the connection for adding electro-valve 24VDC	
	Type	Part number
EHV 2,5 up to 10 L G1"1/4	DI24EYS/1/210CV	35129031G02
EHV 2,5 up to 10 L G1"1/4	DI24EYS/1/250CV	35129031H02
EHV 2,5 up to 10 L G1"1/4	DI24EYS/1/330CV	35129031J02
EHV 2,5 up to 10 L G1"1/4	DI24EYS/1/350CV	35129031Y02
EHV 10 up to 50 L G2"	DI24EYS/3/210CV	35129033G02
EHV 10 up to 50 L G2"	DI24EYS/3/250CV	35129033H02
EHV 10 up to 50 L G2"	DI24EYS/3/330CV	35129033J02
PISTON ACCUMULATOR 10 up to 50 L G2"&EBV 100 and 200 L	Consult Division	

Options or Accessories

Type	Electro valve tension	Part number
ELECTRO-VALVE T3	24 VCC	35157700281
ELECTRO-VALVE T3	110/120 V 50/60 Hz	35157800281
ELECTRO-VALVE T3	220/230 V 50/60 Hz	35157900281
FLOW CONTROL	R24	35067500281
FLANGE M 1"1/4 GAZ CYL CONNECTION ACCUMULATOR SIDE		10436600281
FLANGE M 2" GAZ CYL CONNECTION ACCUMULATOR SIDE		35037500281
RELIEF VALVE CE	210 BAR	35045932102
RELIEF VALVE CE	250 BAR	35045932502
RELIEF VALVE CE	330 BAR	35045933302
RELIEF VALVE CE	350 BAR	35045933502



Safety Block DI 32

TECHNICAL DATA DI 32

- **Size:** Nominal diameter : 32 mm
- **Maxi working pressure:** Manual version : 400 bar
Electrical version : 350 bar
According with the fluids of group 2 (PED)
- **Weight without connector:** Manual version : 11,7 kg
Electrical version : 12,2 kg
- **Materials:** Carbon steel
- **Temperature:** Manual version : - 10°C à + 70°C
Electrical version : - 10°C à + 60°C (ambient temperature)
- **Electrical data:** DC : 24 V
AC : 230 V-50/60 Hz
Standard protection : IP 65
Standard connector : DIN 43650
- **Connection accumulator side:** See page 123
- **Pressure / return connector of circuit:** See hydraulic drawing
- **Pressure relief valve EC (nominal dia):** 10 mm
- **Flow:** Consult the diagram

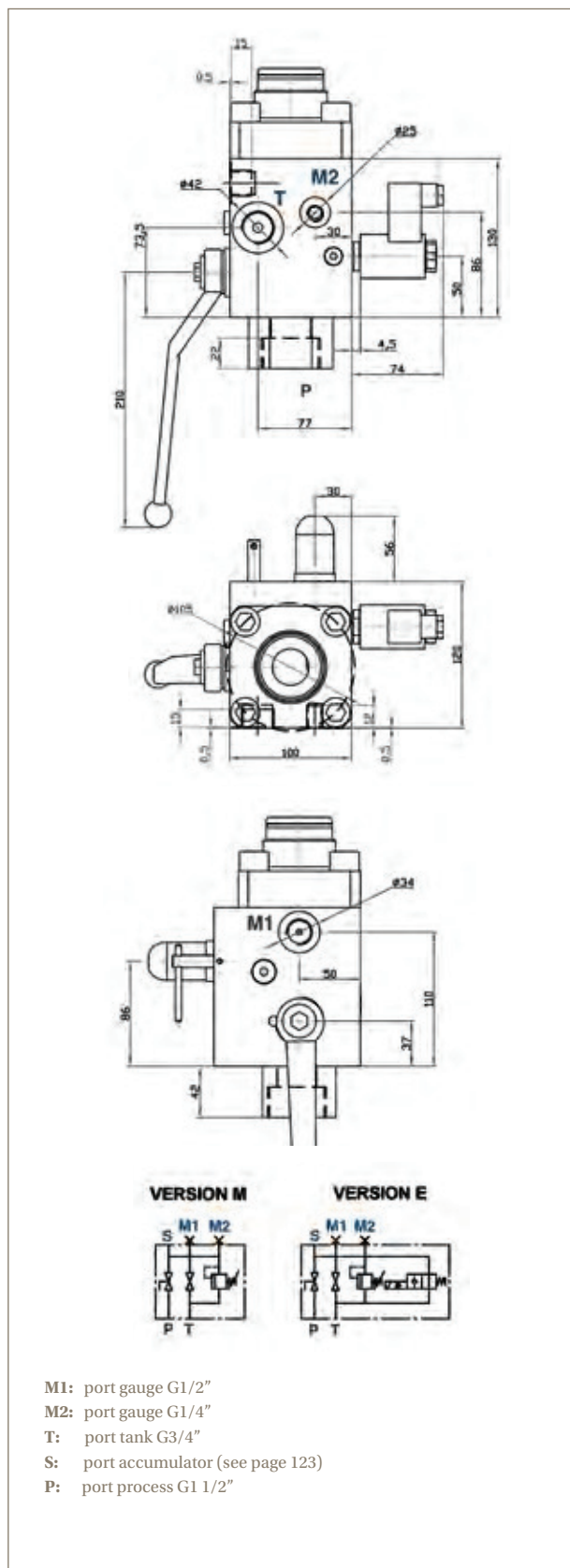
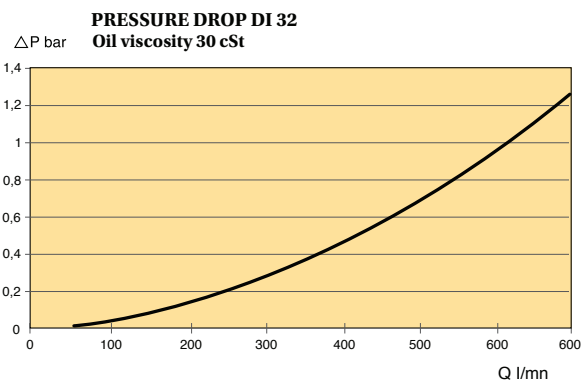

Above dimensions are in mm and are subject to manufacturing tolerances.

Safety Block DI 32 Manual Version

Standard version (Carbon steel, rings NBR) temperature -10°C up to 70°C Maximum working pressure : 400 Bar
According to PED 97/23/CE, EN 14359 Fluid Group 2

Part numbers

Connecting to accumulator	Type	Part number
EHV 2,5 up to 10 L G1"1/4	DI32MS/1/210CH	35172311G01
EHV 2,5 up to 10 L G1"1/4	DI32MS/1/250CH	35172311H01
EHV 2,5 up to 10 L G1"1/4	DI32MS/1/330CH	35172311J01
EHV 2,5 up to 10 L G1"1/4	DI32MS/1/350CH	35172311Y01
EHV 10 up to 50 L G2"	DI32MS/3/210CH	35172313G01
EHV 10 up to 50 L G2"	DI32MS/3/250CH	35172313H01
EHV 10 up to 50 L G2"	DI32MS/3/330CH	35172313J01

Safety Block DI 32 Electrical Version

Standard version (Carbon steel, rings NBR) temperature -10°C up to 60°C Maximum working pressure : 350 Bar
According to PED 97/23/CE, EN 14359 Fluid Group 2

Part numbers

Connecting to accumulator	With Electro-valve tension 24VDC		With Electro-valve other tensions	
	Type	Part number	Type	Part number
EHV 2,5 up to 10 L G1"1/4	DI32EYS/1/210CH24VCC	35172331G21	DI32EYS/1/210CH230V50/60	35172331G61
EHV 2,5 up to 10 L G1"1/4	DI32EYS/1/250CH24VCC	35172331H21	DI32EYS/1/250CH230V50/60	35172331H61
EHV 2,5 up to 10 L G1"1/4	DI32EYS/1/330CH24VCC	35172331J21	DI32EYS/1/330CH230V50/60	35172331J61
EHV 2,5 up to 10 L G1"1/4	DI32EYS/1/350CH24VCC	35172331Y21	DI32EYS/1/350CH230V50/60	35172331Y61
EHV 10 up to 50 L G2"	DI32EYS/3/210CH24VCC	35172333G21	DI32EYS/3/210CH230V50/60	35172333G61
EHV 10 up to 50 L G2"	DI32EYS/3/250CH24VCC	35172333H21	DI32EYS/3/250CH230V50/60	35172333H61
EHV 10 up to 50 L G2"	DI32EYS/3/330CH24VCC	35172333J21	DI32EYS/3/330CH230V50/60	35172333J61

Options or Accessories

Type	Characteristics	Part number
RELIEF VALVE CE	210 BAR	35045932102
RELIEF VALVE CE	250 BAR	35142012502
RELIEF VALVE CE	330 BAR	35142013302
RELIEF VALVE CE	350 BAR	35045933502



Accessories

SBA Series Safety Block

TECHNICAL DATA SBA SAFETY BLOCK

- **Construction**
 - shut-off valve: ball valve
 - pressure relief: poppet-type valve with damping
 - manually-operated discharge valve: poppet-type valve
 - electrically-operated discharge valve: poppet-type valve (where fitted)
- **Port type**
see table below
- **Mounting position**
Accumulator port A facing upwards
- **Mounting screws (not supplied)**
M8 to grade 10.9, max. torque 26 + 4Nm
- **Ambient temperature**
-30°C to +80°C
- **Max. operating pressure**
350 bar
- **Relief flow rate G at pnom**
see table below
- **Fluid**
Mineral oil according to DIN/ISO. For other fluid types, please contact the Parker.
- **Operating temperature**
-15°C to +80°C
- **Viscosity**
10 to 800 mm²/s
- **Δp-Q-graphs**
see right side of this page
- **Electrical discharge**
U=24VDC, 105VDC (for 115V/60 Hz AC supply), P=26W, 100% ED, IP 65 to DIN 40050, connector to DIN 43650 type A
- **Finish**
Black zinc phosphated
- **Seal material**
Nitrile

Flow - Accumulator (A) to Pressure Port (P)

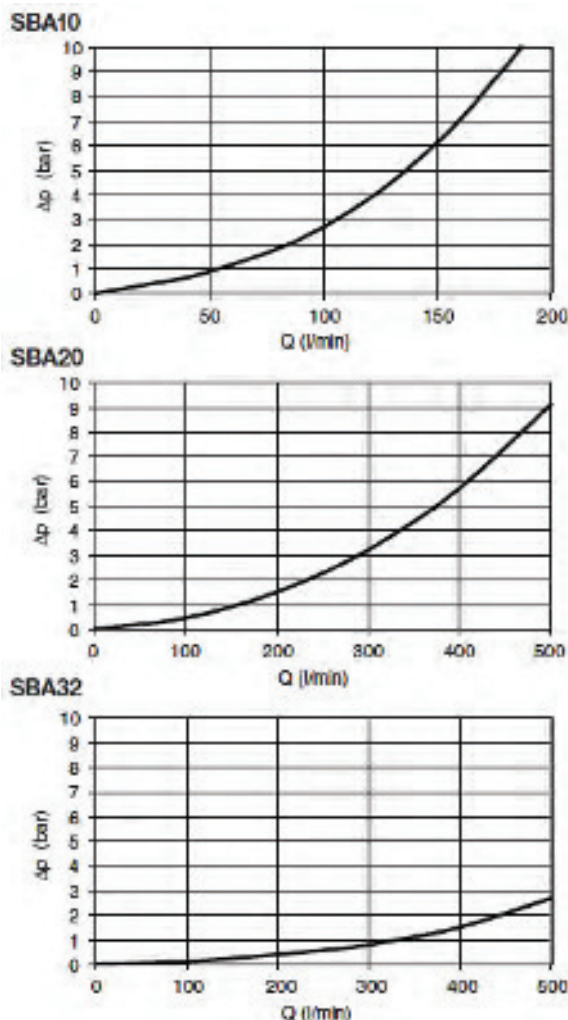

Dimension and Weights

Type	A ¹	P	T	M1	M2	Weight (Kg)	Model Number ²
10M	M33x2	G1/2	G3/8	G1/2	G1/4	4.4	SBA10MT1 - xxx
10E	M33x2	G1/2	G3/8	G1/2	G1/4	4.7	SBA10ET1 - xxx
20M	M33x2	G1	G1/2	G1/2	G1/4	6.0	SBA20MT1 - xxx
20E	M33x2	G1	G1/2	G1/2	G1/4	6.5	SBA20ET1 - xxx
32M	Flange	G1 1/2	G1	G1/2	G1/4	12	SBA32MT1 - xxx
32E	Flange	G1 1/2	G1	G1/2	G1/4	12.6	SBA21ET1 - xxx

¹ A range of adapters is available for accumulator port A - Consult Division

² xxx = pressure setting of pressure relief valve - Consult Division

SBA Type M
Manually-Operated Discharge Valve



SBA Type E
Manually- and Electrically-Operated Discharge Valves

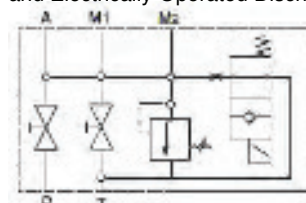

Accessories

Pressure Relief Valve

The function of the pressure relief valve is to protect the accumulator in service. If pressure exceeds the relief valve setting, the valve lifts off its seat and fluid is discharged to tank, allowing pressure in the system to fall to a safe level.

Because of its cartridge design, the pressure relief valve can be readily replaced by a valve with a different pressure setting, selected from the table. A new approval under PED 97/23/EC is not required following this change. The pre-set relief pressure, in bar, is stamped onto the identification plate.

Pressure P (bar)	Item Number
50	SV050
70	SV070
100	SV100
120	SV120
140	SV140
160	SV160
200	SV200
210	SV210
250	SV250
280	SV280
300	SV300
330	SV330

Type Approval

The pressure relief valve is checked and security sealed following approval, according to pressure vessel regulations. It carries a CE mark, type approval number and serial number. All valves are supplied with a certificate showing the pressure setting. The documents supplied with the pressure relief valve must be retained, as they will be required in the event of repeat tests.

Flow Limits for Safety Valve SV - All Models

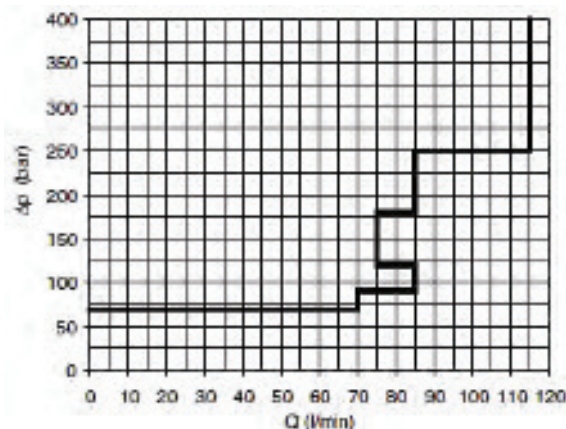

SBA Series: How to order a SBA Safety Block

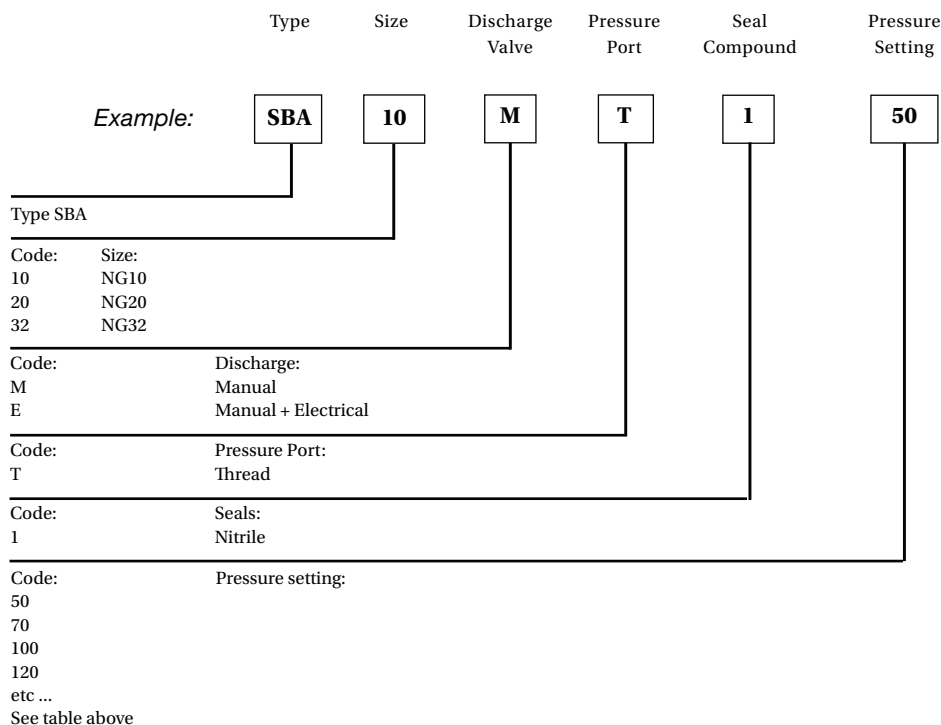

SBA10MT1

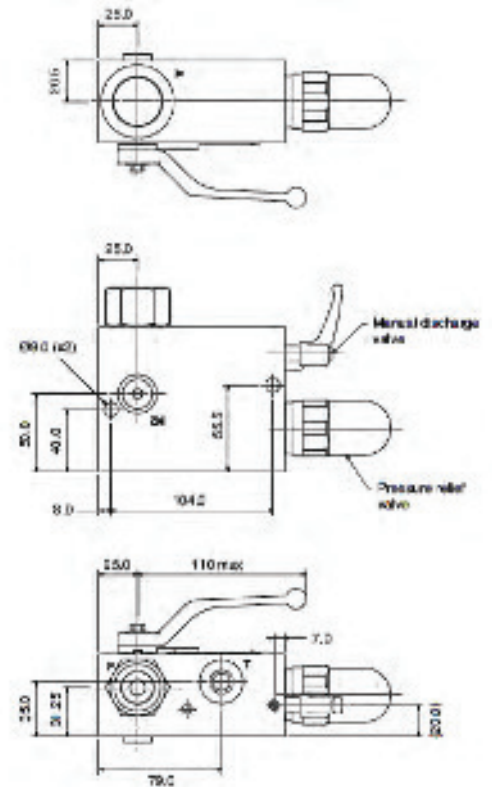
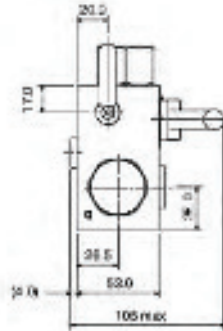
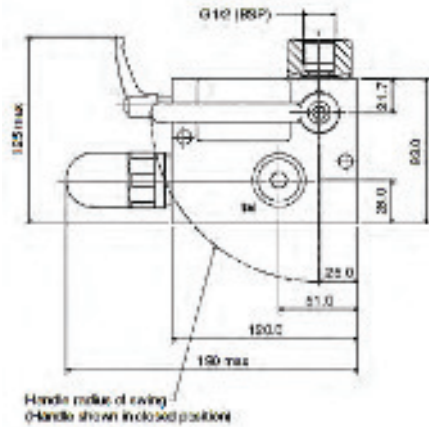

SBA10ET1

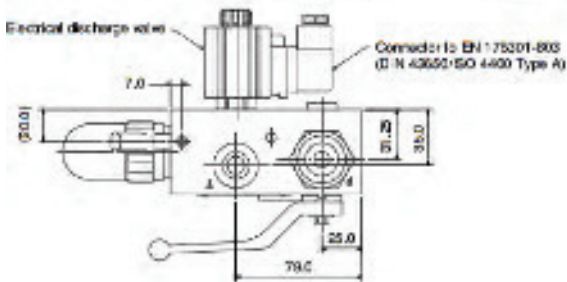
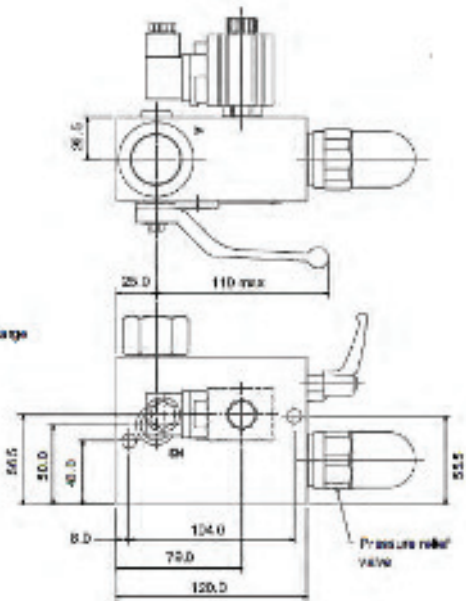
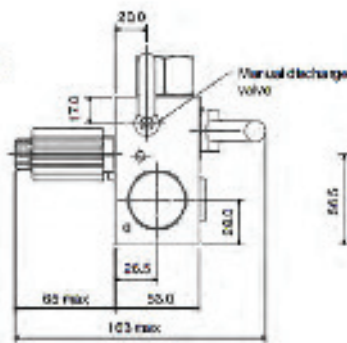
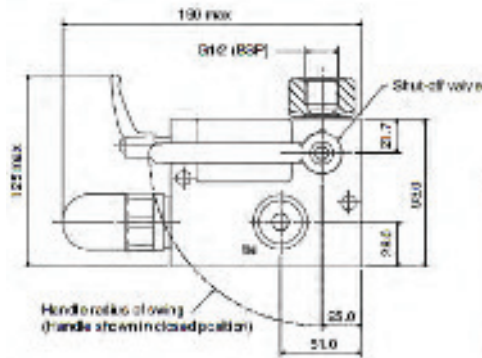

Above dimensions are in mm and are subject to manufacturing tolerances.

SBA20MT1

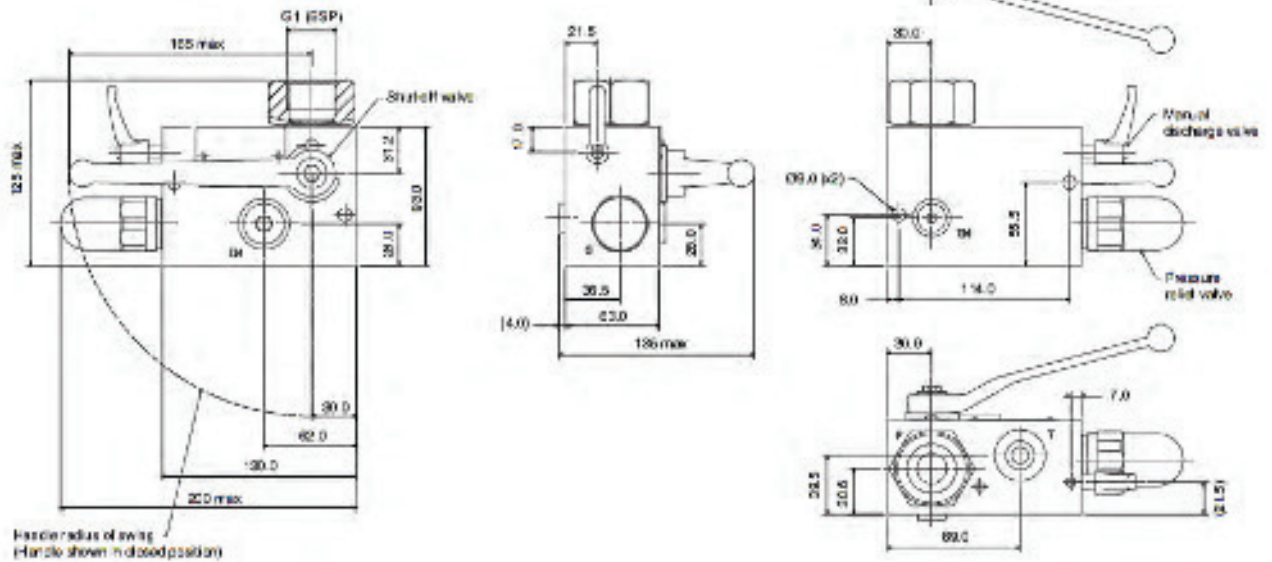

SBA20ET1

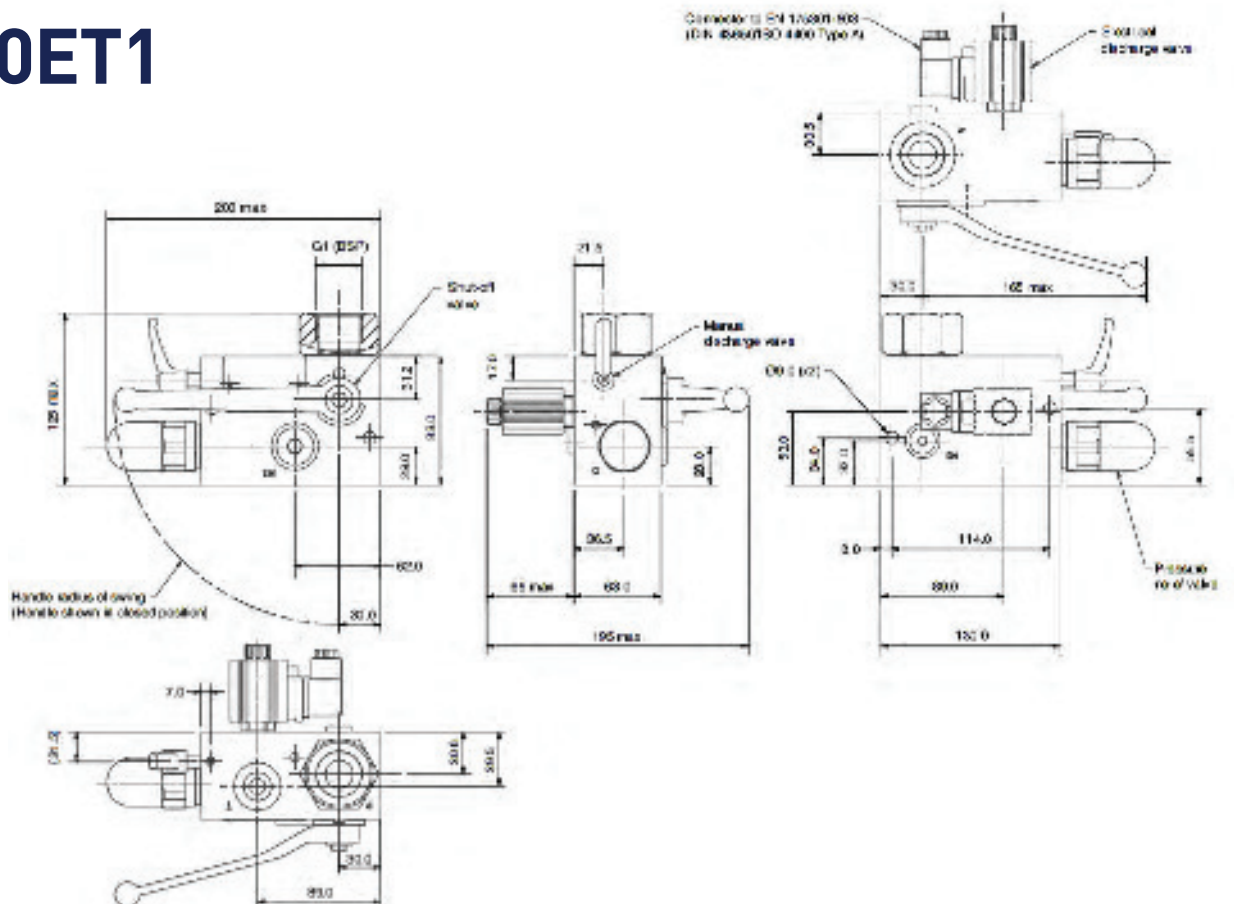

Above dimensions are in mm and are subject to manufacturing tolerances.

SBA32MT1

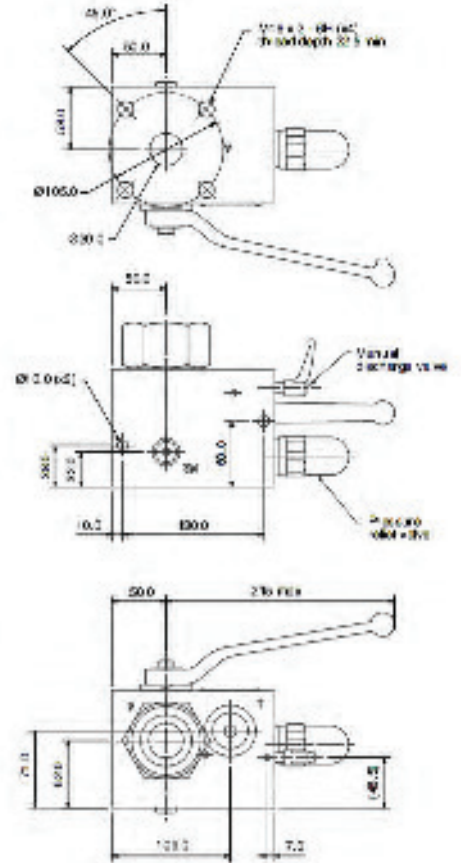
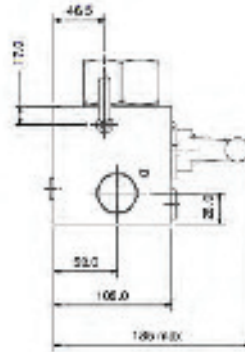
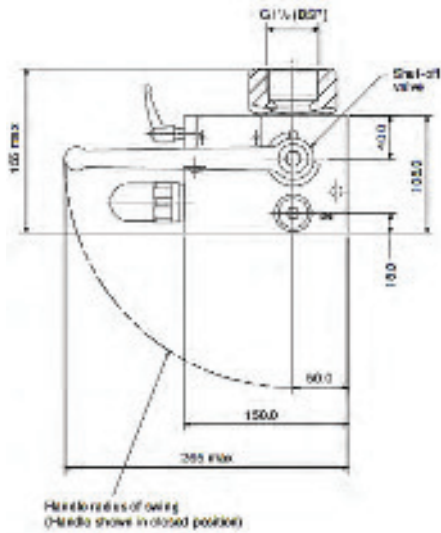

SBA32ET1

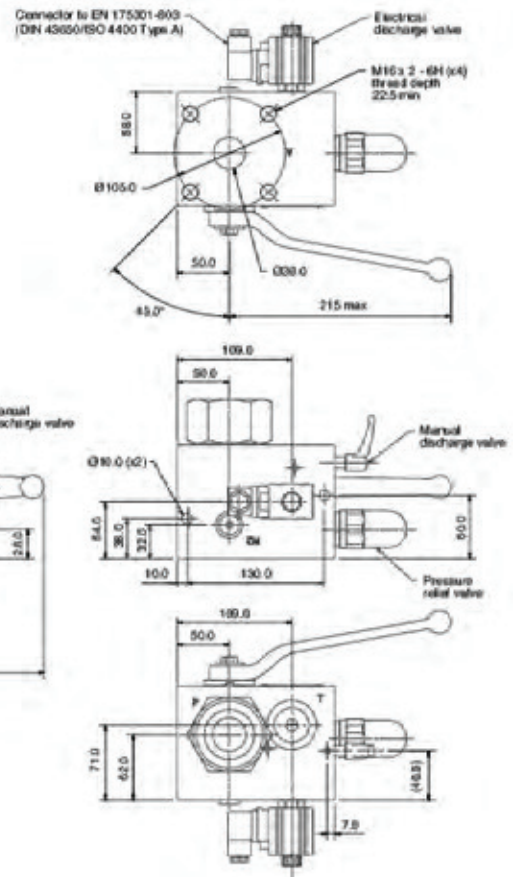
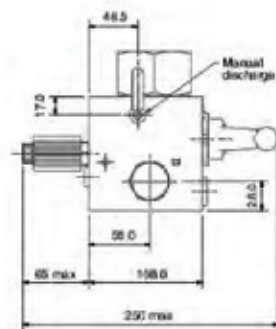
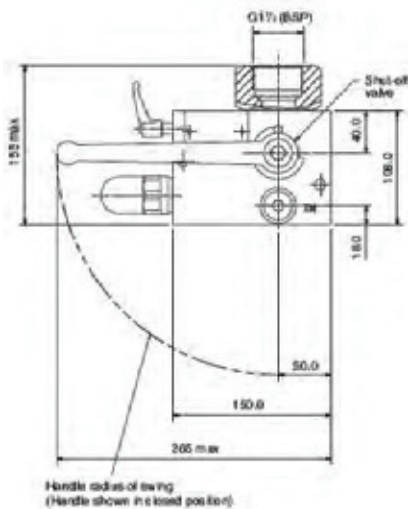

Above dimensions are in mm and are subject to manufacturing tolerances.

Accessories

Adapters - Accumulator to Safety Block

Accumulator Fluid Port D1		Safety Block Port A	SW	L	L1	D2	D3	Weight (Kg)	Part Number	Use with SBA	For Accumulator Type		
											Bladder	Diaphragm	Piston
G3/4	ISO 228	M33 x2	46	33	16	53	16	0.4	UEST-T-3/4	10 & 20	x		
G1 1/4	ISO 228	M33 x2	55	41	20	63	20	0.4	UEST-T-1 1/4	10 & 20	x		
G2	ISO 228	M33 x2	80	46	22	90	20	1.5	UEST-T-2	10 & 20	x		
G2	ISO 228	Flange 100	-	50	22	-	30	2.2	UEST-F-2	32	x		
G1/2	ISO 228	M33 x2	46	34	14	53	12	0.4	UEST-T-1/2ED	10 & 20		x	x
G3/4	ISO 228	M33 x2	46	36	16	53	16	0.4	UEST-T-3/4ED	10 & 20		x	x
G1 1/2	ISO 228	Flange 100	-	70	22	-	30	2.3	UEST-F-1 1/2	32			x

Threaded Adapter
 UEST-T-xx

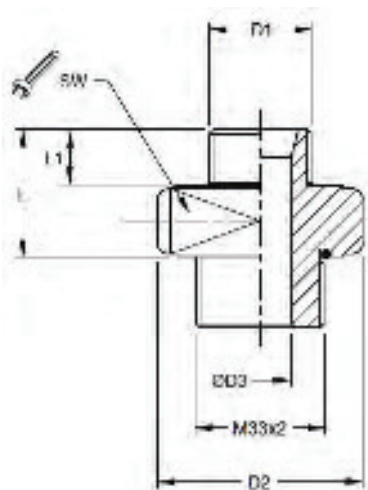

Flanged Adapter
 UEST-F-xx

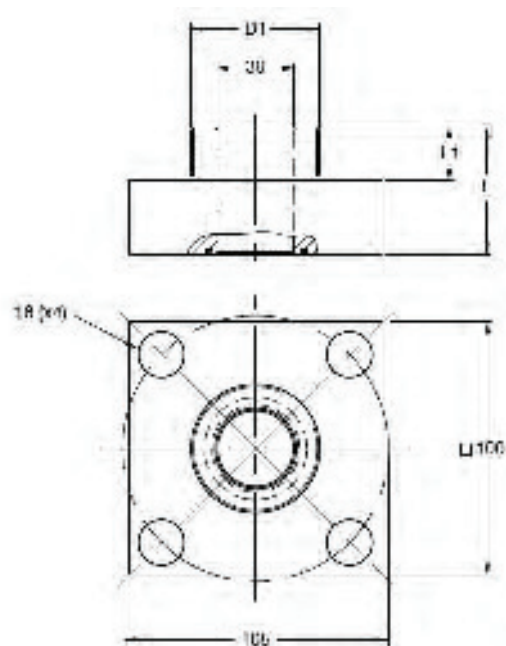

Above dimensions are in mm and are subject to manufacturing tolerances.

ECA & ECSA Series Safety Block

TECHNICAL DATA CARBON STEEL SAFETY BLOCK (345 BAR)

Maximum working pressure: 345 bar

Materials: Carbon steel. All blocks are fully tested.

Seals: Nitrile fitted as standard. Viton and other options also available.

Connections :

- Pressure gauge connection (M port).
- Wide range of adaptors for accumulator connection.
- All G threads (BSP) to BS2779 1986. Performance data available.

Other:

- Pressure relief valve for the protection of accumulator.
- Manual dump to tank valve as standard.
- Optional additional electromagnetic dump to tank valve.

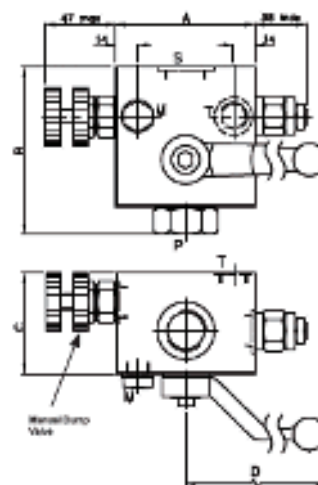

TECHNICAL DATA STAINLESS STEEL SAFETY BLOCK (345 BAR & 690 BAR)

Materials: 316 Stainless steel. All blocks are fully tested.

Seals: Nitrile fitted as standard. Viton and other options also available.

Connections :

- Pressure gauge connection (M port).
- Wide range of adaptors for accumulator connection.
- All G threads (BSP) to BS2779 1986.
- For 760 bar only - All NPT to ANSI/ASME B.1.20.1 1983
- Performance data available.

Other:

- Pressure relief valve for the protection of accumulator.
- Manual dump to tank valve as standard.

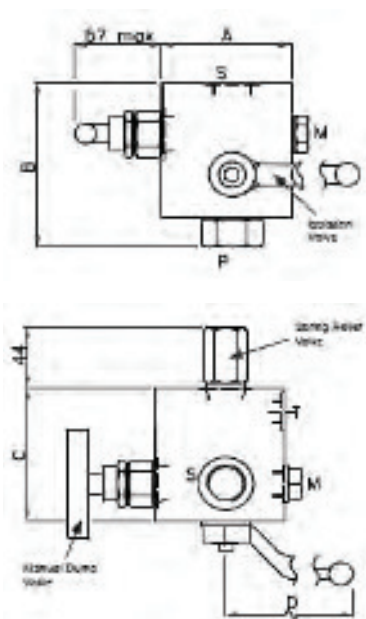

Accessories

EC(S)A Series: How to order an ECA or ECSA Safety Block

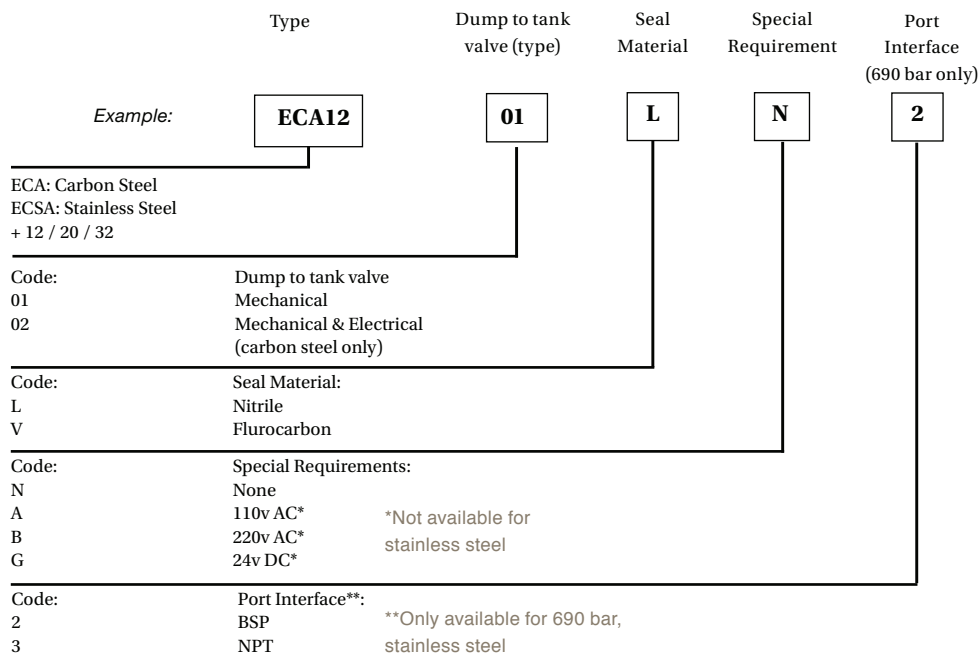

ECA, Carbon Steel, 345 Bar

Part Number	Port Sizes				Dimensions (mm - for standard (01) Safety Block)			
	S port Accumulator	P port process	T port tank	M port Gauge	A	B	C	D Handle Length
ECA12-01-L-N	G 1/2"	G 1/2"	G 1/4"	G 1/4"	76	93	60	115
ECA20-01-L-N	G 3/4"	G 3/4"	G 3/8"	G 1/4"	90	108	70	160
ECA32-01-L-N	G1 1/4"	G1 1/4"	G 3/8"	G 1/4"	90	131	90	300

ECSA, Stainless Steel, 345 Bar

Part Number	Port Sizes				Dimensions (mm - for standard (01) Safety Block)			
	S port Accumulator	P port process	T port tank	M port Gauge	A	B	C	D Handle Length
ECSA12-01-L-N	G 1/2"	G 1/2"	G 1/4"	G 1/4"	65	94	76	115
ECSA20-01-L-N	G 3/4"	G 3/4"	G 3/8"	G 1/4"	70	108	90	160
ECSA32-01-L-N	G1 1/4"	G1 1/4"	G 3/8"	G 1/4"	90	131	105	300

ECSA, Stainless Steel, 690 Bar

Part Number	Port Sizes				Dimensions (mm - for standard (01) Safety Block)			
	S port Accumulator	P port process	T port tank	M port Gauge	A	B	C	D Handle Length
ECSA12-01-L-N-2	G 1/2"	G 1/2"	G 1/4"	G 1/4"	70	94	85	115
ECSA12-01-L-N-3	1/2" NPT	1/2" NPT	1/4" NPT	1/4" NPT	70	94	85	115

• All NPT to ANSI/ASME B.1.20.1. 1983

• All G threads (BSP) to BS2779 1986

EHB Series, 1.6 to 10 Litres, 350 bar

Standard Version (**Carbon Steel** shell) for mineral oils temperature from - 40° up to 80°C

According to PED 97/23/EC

Part numbers, Accessories, Dimensions

Type	Part number	Complete Repair Kit	
		Model	Part number
EHB 1.6-350/90*	11006501125	KIT EHB 1.6-350/90*	19067801125
EHB 2.5-350/90*	10940901125	KIT EHB 2.5-350/90*	19067901125
EHB 5-350/90**	10941001125	KIT EHB 5-350/90	19067901125
EHB 4-350/90**	10987101125	KIT EHB 4-350/90**	19068001125
EHB 6-350/90**	10954101125	KIT EHB 6-350/90**	19068001125
EHB 10-350/90***	10936001125	KIT EHB 10-350/90***	19068001125

* EN 14359 Fluid Group II

** EN 14359 Fluid Group III

*** EN 14359 Fluid Group IV

Temperature range can be narrowed depending on elastomer.

Type	Effective Gas vol. Litres	Max. Working pressure (PS) bar	Max Flow Rate lt/min	Max Weight kg	Top connection	Dimensions in mm						
						A max height	B	C	øD max	øE	F on flats	øG connection
EHB 1.6-350/90*	1.6	350	240	7	1/2" 20 UNF	414	54	40	116	50	32	G 3/4"
EHB 2.5-350/90*	2.4	350	450	10	1/2" 20 UNF	521	66	40	116	68	50	G 1 1/4"
EHB 5-350/90**	5	350	450	16	1/2" 20 UNF	870	66	40	116	68	50	G 1 1/4"
EHB 4-350/90**	3.7	350	450	14	1/2" 20 UNF	406	65	40	170	68	50	G 1 1/4"
EHB 6-350/90**	6	350	450	19	1/2" 20 UNF	532	65	40	170	68	50	G 1 1/4"
EHB 10-350/90***	10	350	450	29	1/2" 20 UNF	797	65	40	170	68	50	G 1 1/4"



EHB Series, 10 to 57 Litres, 330 bar

Standard Version (**Carbon Steel** shell) for mineral oils temperature from - 40° up to 80°C

According to PED 97/23/EC, EN1439 Fluid Group IV

Part numbers, Accessories, Dimensions

Type	Part number	Complete Repair Kit	
		Model	Part number
EHB 10-330/90	10949501125	KIT EHB 10-330/90	19060401125
EHB 12-330/90	10993401125	KIT EHB 12-330/90	19060401125
EHB 20-330/90	10933901125	KIT EHB 20-330/90	19060401125
EHB 24.5-330/90	Consult Division	KIT EHB 24.5-330/90	19060401125
EHB 32-330/90	10935901125	KIT EHB 32-330/90	19060401125
EHB 42-330/90	11181801125	KIT EHB 42-330/90	19060401125
EHB 50-330/90	11137501125	KIT EHB 50-330/90	19060401125
EHB 57-330/90	11181901125	KIT EHB 57-330/90	19060401125

Type	Effective Gas vol. Litres	Max. Working pressure (PS) bar	Max Flow Rate lt/min	Max Weight kg	Top connection	Dimensions in mm						
						A max height	B	C	øD max	øE	F on flats	øG connection
EHB 10-330/90	9.2	330	900	29	1/2" 20 UNF	554	103	40	226	101	70	G 2"
EHB 12-330/90	11	330	900	34	1/2" 20 UNF	654	103	40	226	101	70	G 2"
EHB 20-330/90	17.8	330	900	46	1/2" 20 UNF	864	103	40	226	101	70	G 2"
EHB 24.5-330/90	22.5	330	900	53	1/2" 20 UNF	999	103	40	226	101	70	G 2"
EHB 32-330/90	32	330	900	76	1/2" 20 UNF	1387	103	40	226	101	70	G 2"
EHB 42-330/90	42	330	900	82	1/2" 20 UNF	1529	103	40	226	101	70	G 2"
EHB 50-330/90	48.5	330	900	105	1/2" 20 UNF	1903	103	40	226	101	70	G 2"
EHB 57-330/90	51	330	900	110	1/2" 20 UNF	1999	103	40	226	101	70	G 2"



BA series, 50 Litres, 360 bar

Standard version (**Carbon Steel** shell), temperature from -40° up to 80°C

According to PED 97/23/EC, Fluid Group 2

Part numbers, Dimensions

Type	Effective Gas vol. Litres	Design P bar	Weight kg	L (mm) ± 30	øE max (mm)	Top Connection	Bottom Connection
Part number BA 50-360/90 0957036CE1100H	50	360	95	1800	220	G 1 1/2"	G 3/4"



EHB series, 50 to 100 Litres, 350 bar & 3050 PSI (APP22)

Standard version (**Carbon Steel** shell) temperature from -40° up to 80°C.

According to PED 97/23/EC and ASME CODE SEC VIII DIV.1

Part numbers, Dimensions

Type Part number	Effective Gas vol. Litres	Max. Working pressure (PS) bar	Max. Working pressure (PS) psi APP22	Max Weight kg	Top connection	Bottom connection	øE max mm	L mm
EHB 50-350/86 11182901125	49.6	350	2970	94	G1 1/2"	G 3/4"	222	1800
EHB 50-350/90 11183201125	50.7	412	-	100	G1 1/2"	G 3/4"	221	1800
EHB 75-350/86 11183001125	73.2	350	2900	134	G1 1/2"	G 3/4"	275	1720
EHB 100-350/86 11183101125	97.9	350	3050	180	G1 1/2"	G 3/4"	360	1420

